

Panasonic

CORDLESSPHONE

MODEL NO. **KX-T3726**

Easa-Phone

PLEASE READ BEFORE USE

Operating Instructions



Please read before use.

Charge the battery for about 10 hours before initial use.

Important information

APPROVED for connection to telecommunication systems specified in the instructions for use subject to the conditions set out in them.

S/1010/3/P/502948

Do not connect the AC adaptor to any AC outlet other than the standard AC 240 V, 50 Hz.

- Outlet voltage DC 12 V, 150 mA
- The apparatus is approved for use with the KX-A14BE and KX-A91E power supply.
- CAUTION: Do not remove cover. Live parts inside.

Ringer Equivalence Number (REN):

This relates to the performance of the apparatus when used in combination with other items of apparatus. It enables the calculation of the maximum number of items of apparatus that may be connected simultaneously to the line by summing the REN values of each item. A BT supplied instrument has a REN value of 1 unless otherwise marked. A maximum REN value of 4 should not be exceeded. The REN value of the apparatus is 1.

Method of connection

This is connected to the exchange line or PABX/PMBX (Private Automatic/Manual Branch Exchange) extension by the new standard British Telecom plug and socket. Arrangements for provision of this type of termination can be made through the nearest British Telecom Sales Office. The apparatus may be connected to the following types of installation. The apparatus has been approved for use under the following conditions:

- a) For connection to the public switched telephone network (PSTN) and compatible PBX (Private Branch Exchange), which use LD signalling and MF signalling. (Please consult your supplier for an up to date list of compatible PBX's.)
- b) The apparatus can be used on extension sockets connected to a direct exchange line (D.E.L.).
- c) This apparatus is suitable for connection to the telecommunication system directly or via compatible private branch exchange as an extension. The supplier of the apparatus should be consulted for an up to date list of PBX's with which the apparatus is compatible.

- d) This apparatus must not be connected in the following manner:
- 1) As an extension to a pay phone
 - 2) As a party line with shared service

It cannot be guaranteed that the apparatus will operate under all possible conditions of connection to compatible PBX's.

- This apparatus is suitable for connection to a PBX with or without initial proceed indication.
- This apparatus is suitable for connection to a PBX with or without secondary proceed indication.

Interconnection directly, or by way of other apparatus, of ports marked "SAFETY WARNING. See instructions for use." with ports not so marked may produce hazardous conditions on the network and advice should be obtained from a competent engineer before such a connection is made.

This cordless telephone has been designed to operate on radio frequencies which have been assigned to the exclusive use of cordless telephones. As the use of cordless telephones becomes more widespread users may experience a reduction in the quality of service obtainable from this apparatus.

You may receive interference on some domestic radio receivers because the cordless telephone transmission is at 1.7 MHz leg.

There is possibility of occurrence of *overhearing* between cordless telephones operating on the same radio channel. And such interference may increase with greater usage of cordless telephones.

This apparatus has been approved for the use of the following facilities:

- 1) Storage of telephone numbers for retrieval by a predetermined code
- 2) Automatic Dialling
- 3) Automatic storage of last number dialled
- 4) Repeat Attempt: Single
- 5) Simple telephone facility
- 6) PBX earth register recall
PBX timed break register recall
- 7) MF Signalling
- 8) LD Signalling
- 9) Mercury dialling compatibility
- 10) Pause
- 11) Intercom

Any other usage will invalidate the approval of the apparatus if as a result, it then ceases to conform to the standards against which approval was granted.

999 or 112 can be dialled on the apparatus for the purposes of making outgoing calls to the BT Emergency (999 or 112) Service.

WARNING:

The apparatus may be unable to make emergency 999 or 112 telephone calls, under certain conditions, e.g.

- Radio interference caused by another cordless telephone operating on the same radio frequency.
- The portable handset battery needs recharging, or has failed.
- The base unit back-up batteries are exhausted. With the batteries in good condition the base unit will be able to operate without mains power for at least seven hours, including one hour in the TALK mode.
- The portable handset cannot be used while charging.

Any cases of difficulty should be referred in the first instance to the supplier of the apparatus.

NOTE:

If you experience any problems with the normal use of your apparatus, you should unplug it from the telephone outlet and connect a known working telephone in its place. If the known working telephone still gives problems, then call British Telecom Engineers. If it operates properly, then the problem is likely to be a fault in your apparatus. In this case, contact your supplier for advice. British Telecom will charge you if they attend a service call that is not due to apparatus supplied by them.

Contents ---

Important information	2
Included with this unit	6
For best performance	7
Battery charge	7
Operating range	8
Noise	9
Location of controls	10
Setting up the unit	12
Connection	12
Setting selectors	16
Making calls	18
Answering calls	20
Automatic dialling	22
Storing phone numbers in memory	23
Dialling a stored number from memory	25
Intercom between the base unit and the portable handset	26
The Mercury Residential Service	28
For Residential 132 Service customers	28
For Residential 2300 Service customers	30
Resetting the Mercury station's memory (Returning to Residential 132 Service)	34
Other features	35
For users of a PBX (PAUSE)	35
Temporary tone dialling (TONE)	35
Using the recall feature (RECALL)	36
Automatic security code setting	36
Battery replacement	37
Wall mounting	38
Troubleshooting guide	40
Safety instructions	42

Included with this unit _____

AC Adaptor.....one
(p. 13)

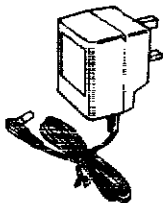

Screws..... two
(p. 38)

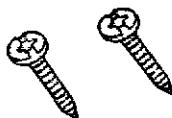

Battery Box.....one
(p. 13, 14)

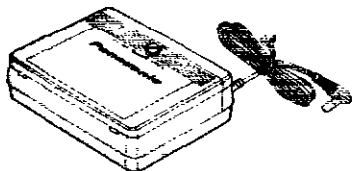

Washers..... two
(p. 38)



Wall Mounting Adaptor.....one
(p. 38)

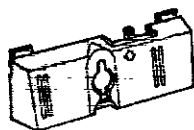

Rechargeable Battery
(KX-A36A).....one
(p. 37)

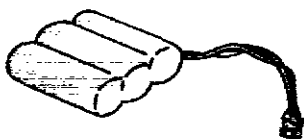

The battery has been installed in the portable handset at the factory.

For best performance

Battery charge

To power the portable handset, charge the battery before initial use.

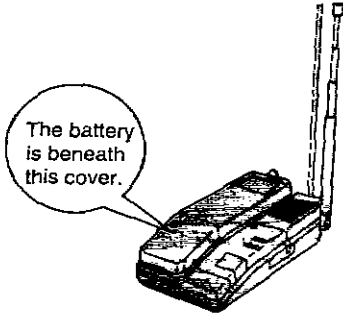

Place the portable handset on the base unit connected to AC power for about 10 hours.

- The CHARGE indicator light is on.
- The battery cannot be overcharged.

Notes:

- For maximum battery life, do not charge it after every telephone call. We recommend you charge it every few days. The battery works best if discharged enough before being recharged.
- Clean the charge contacts with a soft cloth once a month, or the battery may not charge properly.

Recharge is necessary when the BATT LOW/PROG indicator flashes or beep tone sounds every 15 seconds during a conversation.

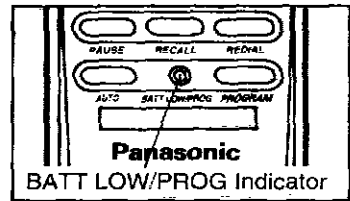

Standard battery life

If your Panasonic battery is fully charged: —

In TALK mode	Up to about 7 hours
In Stand-by mode	Up to 7 days

(Battery life may vary depending on usage condition and surrounding temperature.)

Operating range

Range of operation depends on the construction of your home, weather or usage conditions, because calls are transmitted between the base unit and the portable handset by wireless radio waves.

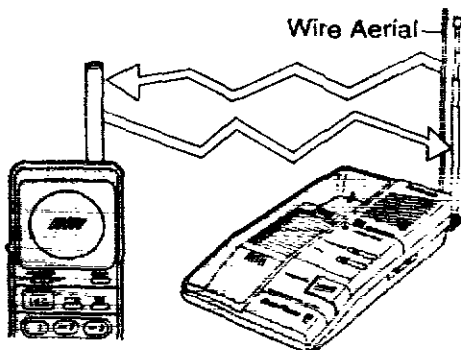

Normally you may get longer range outdoors than indoors. If there are some obstacles such as walls, noise may prevent your telephone calls. In particular, high metal shelves or cement-iron walls will shorten the operating range.

For maximum range

It is best to place the base unit in a HIGH and CENTRAL location of the house, with no obstructions. Be sure to fully extend the aerials of the portable handset and the base unit during use.

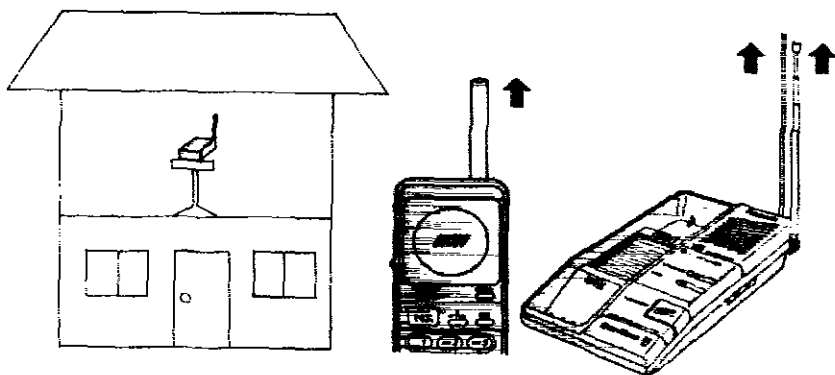

Noise

Occasional noise or interference may occur due to other random radio waves.

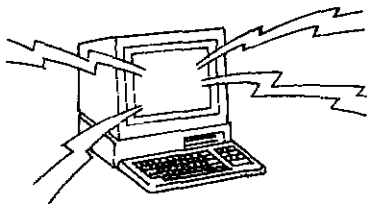

Electrical appliances such as a refrigerator, microwave oven, fax, TV, radio, or personal computer might interfere with the telephone conversation or shorten the operating range.

If noise affects your telephone calls, keep the base unit, telephone line cord or AC adaptor cord away from electrical appliances.

To reduce noise during a conversation (Selecting a clear channel)

A channel is a set of receiving and transmitting frequencies. You may select the clearer of the 2 available channels.

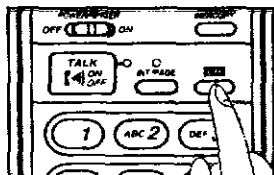

During a conversation, press the CH button.

– Each time you press the button, the other channel is selected.

Note:

– If the portable handset user is too far from the base unit, the CH button may not function fully. Approach the base unit.

Location of controls

Portable handset

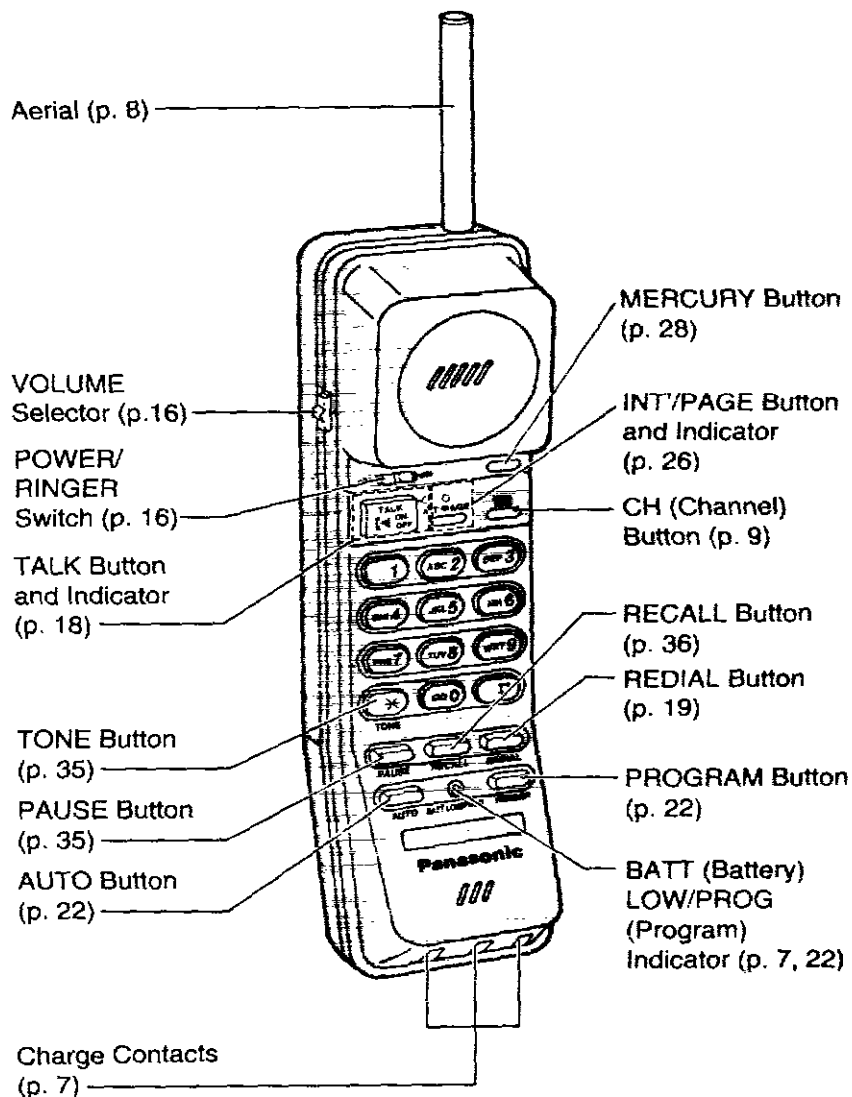

Base unit

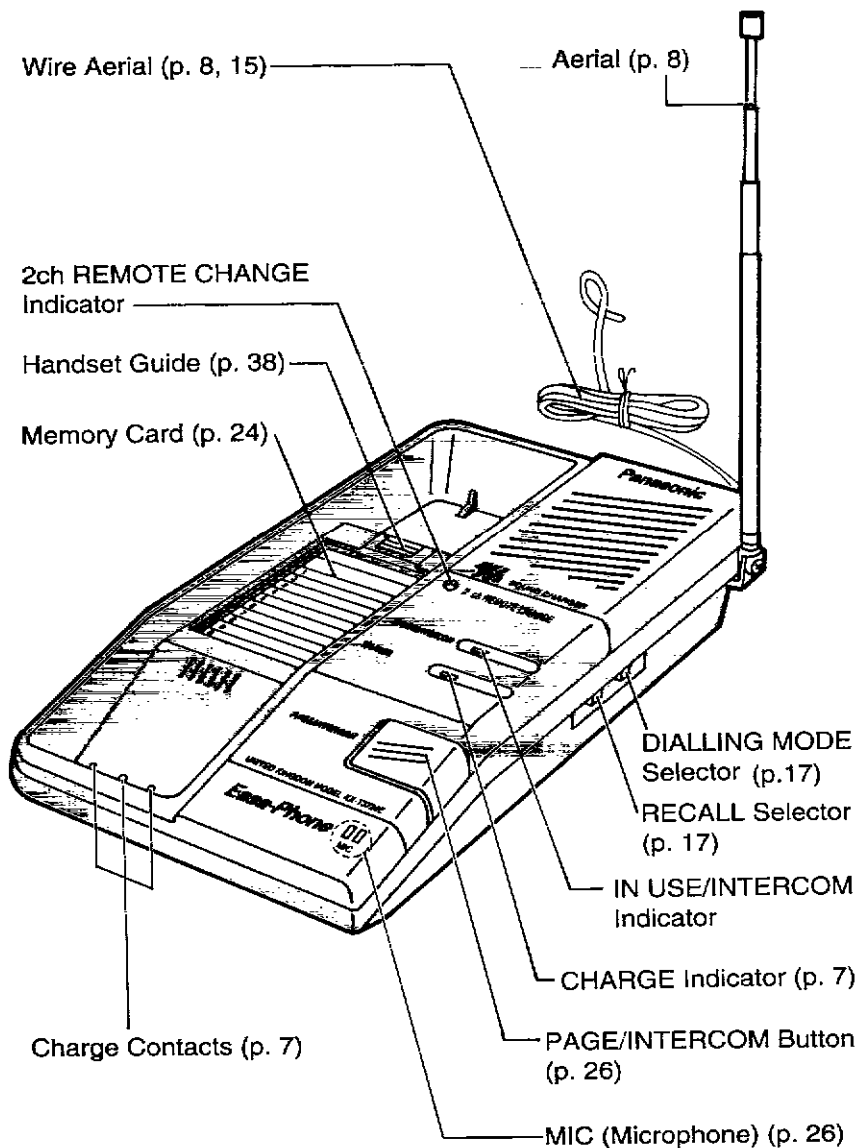

Setting up the unit

Connection

USE ONLY Panasonic AC ADAPTOR KX-A14BE AND BATTERY BOX KX-A91E.

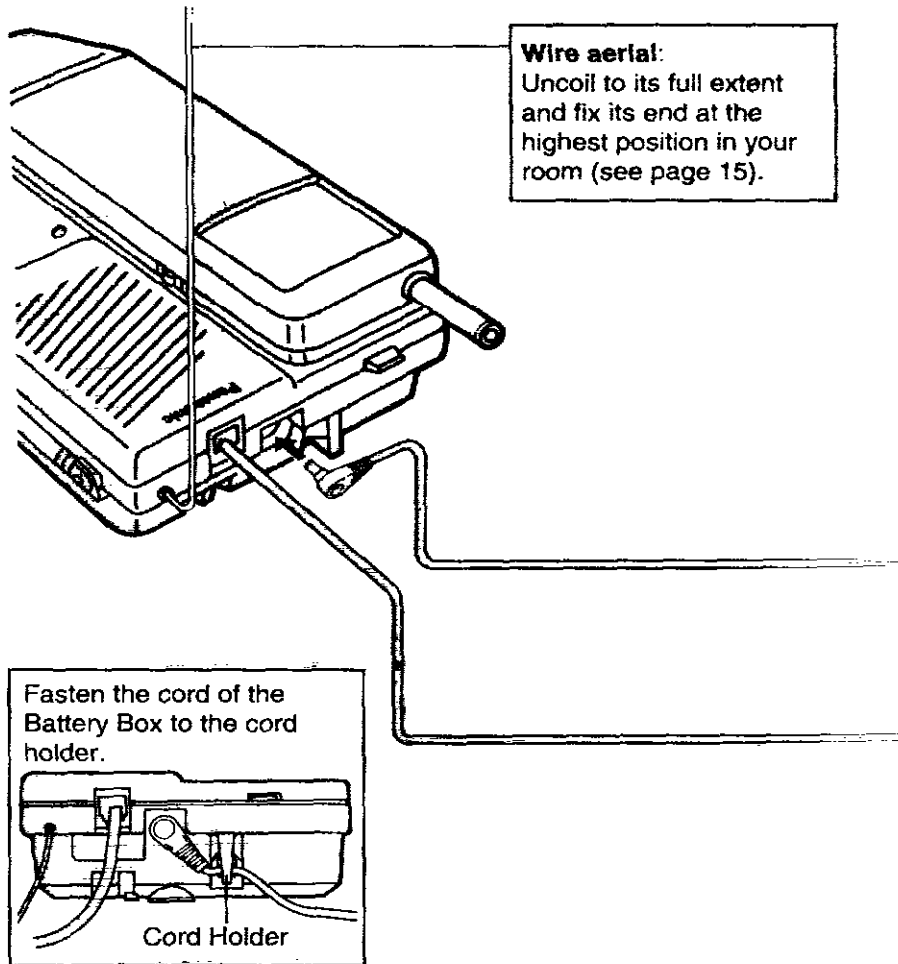

Power failure protection

The unit will not function during a power failure. We recommend that you install eight optional batteries (AA, R6 or UM-3) into the Battery Box. Then, you can operate the unit during a power failure (see page 14).

CONNECTION OF POWER SUPPLY

This apparatus is intended for use when powered by KX-A14BE and KX-A91E. Other usage will invalidate any approval given to this apparatus.

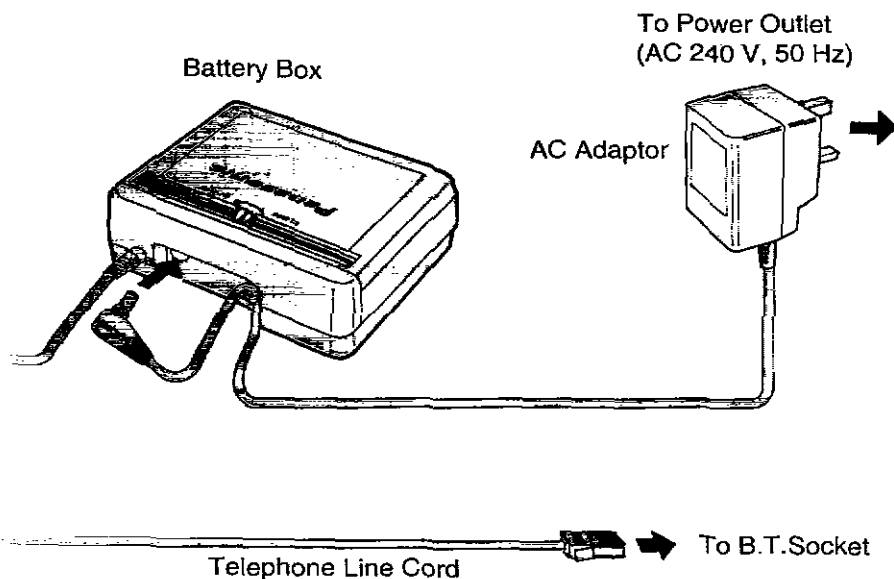

Note:

– The AC adaptor and the Battery Box must remain connected.

Battery installation into the Battery Box

Installing eight optional batteries (AA, R6 or UM-3 size) into the Battery Box enables you to operate the unit during a power failure. You can use the unit for up to about 1 hour when new batteries are installed.

1

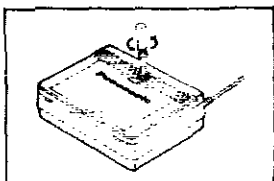

Loosen the screw.

2

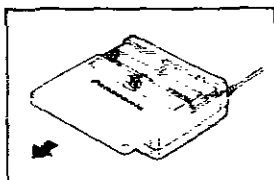

Open the battery compartment as shown.

3

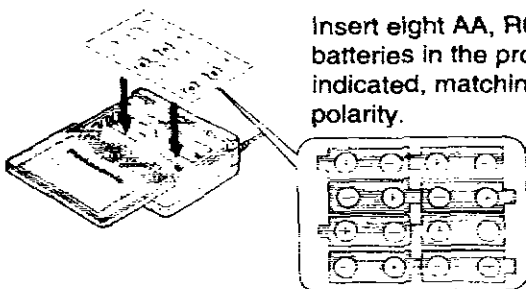

Insert eight AA, R6 or UM-3 size batteries in the proper order as indicated, matching the correct polarity.

– When you finish, close the cover and tighten the screw.

Battery precautions:

The batteries should be used correctly, otherwise, the unit may be damaged due to battery leakage.

- Do not mix old, new or different types of batteries.
- Do not charge, short-circuit, disassemble, heat or dispose in fire.
- Do not use nickel-cadmium batteries.
- Please renew the batteries annually as a matter of routine.
- After a power failure has taken place, you should replace the batteries with new ones.
- Battery life depends on operating temperature and quality of batteries.

To install the wire aerial

The base unit has two types of aerial. One is the wire and the other is telescopic.

The wire aerial is used to transmit sounds to the portable handset while the telescopic aerial is used to receive them from the portable handset.

Uncoil the wire aerial to its full extent and fix its end at the highest position in your room. Avoid metal objects such as window frames for best performance.

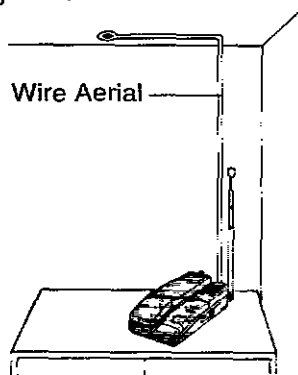

Note:

– Do not cut the wire aerial or connect other wires.

To connect another telephone

To B.T. Socket

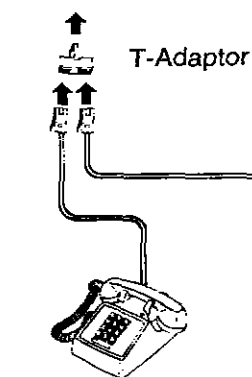

Another Telephone

If you connect a reserve telephone (standard telephone) on the same line, please use a T-adaptor.

Setting selectors

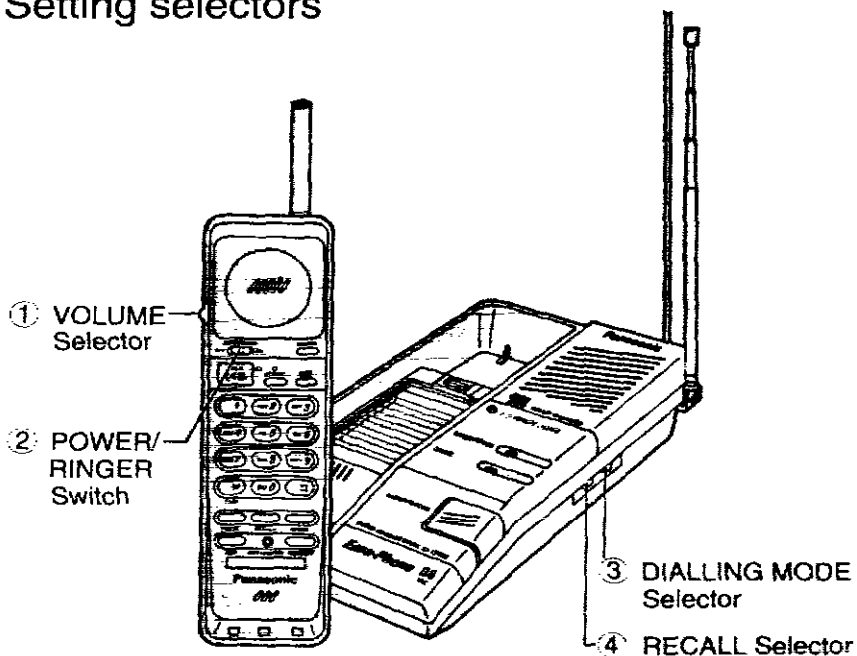

① VOLUME Selector

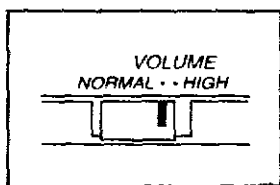

Set to the NORMAL position. If the other party's voice is difficult to hear, set to the HIGH position.

② POWER/RINGER Switch

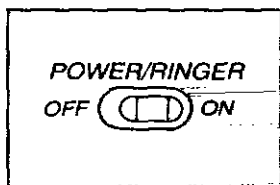

Set to the ON position. If set to the OFF position, battery power will be saved, but the portable handset will not operate or ring.

③ DIALLING MODE Selector

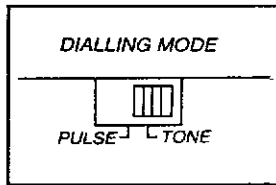

Set to the TONE position when your telephone line has touch tone service. If it has rotary service, set to the PULSE position.

You can ascertain which type of local BT exchange you are connected to using the following procedure.

1. Ensure that the DIALLING MODE selector is set to TONE.
2. Press the TALK button, then identify the dial tone.
3. Dial a number you are familiar with.
4. If the call is successful, you are connected to a Tone exchange, therefore leave the DIALLING MODE selector on TONE.
5. If the call is not successful, you are connected to a Pulse exchange. Therefore, switch the DIALLING MODE selector back to PULSE.

④ RECALL Selector

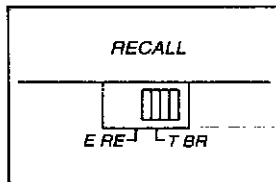

Set to the T BR position if the unit is to be connected directly to an exchange line. If the unit is to be connected via a PBX (switchboard) then you may need to switch to the E RE position. If you are in any doubt, then please contact your switchboard manager or supplier for advice.

Making calls

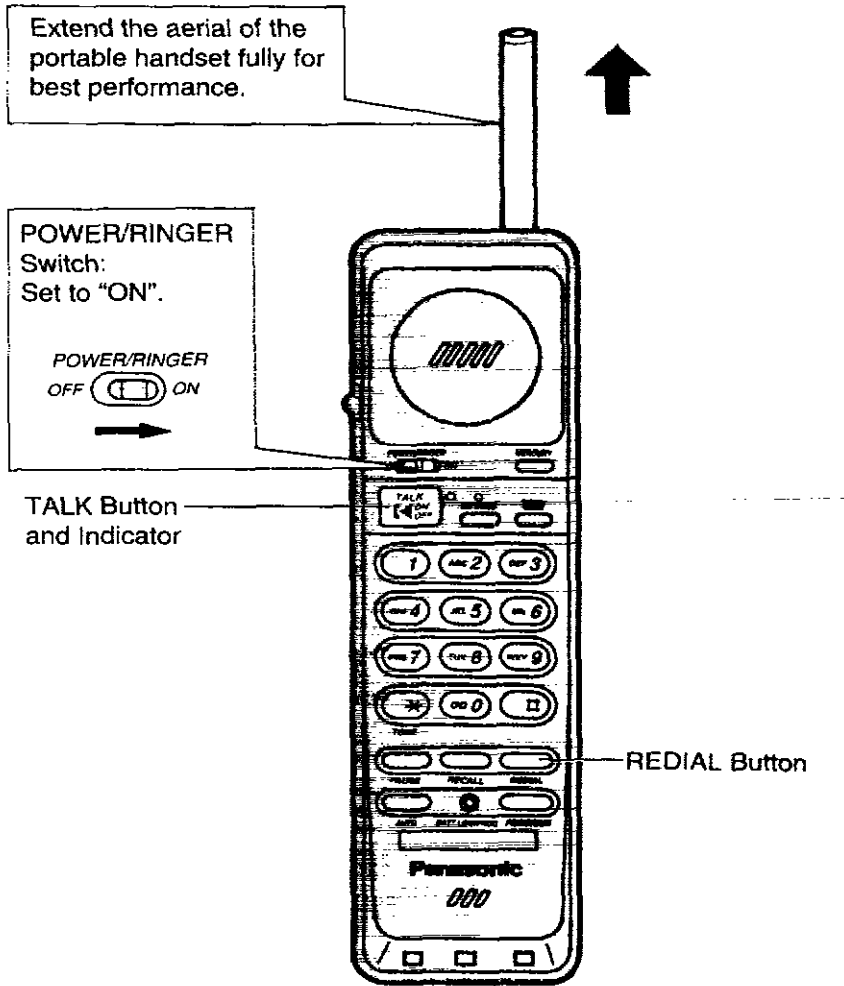

Note:

- If alarm tone sounds when you press the TALK button, approach the base unit or place the portable handset on the base unit. Then try again.

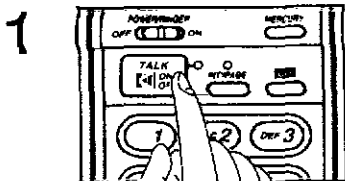

Press the TALK button to get dial tone.

– The TALK indicator light is on.

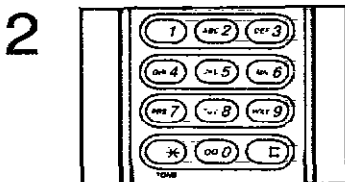

Dial a telephone number.

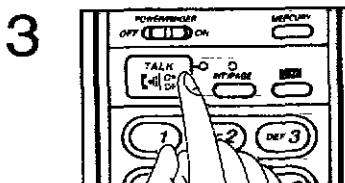

To hang up, press the TALK button or place the portable handset on the base unit.

– The TALK indicator light goes out.

To redial

Press the TALK button to get dial tone, then press the REDIAL button. The last dialed number is automatically redialed.

Answering calls ---

Extend the aerial of the portable handset fully for best performance.



POWER/RINGER Switch:
Set to "ON".

POWER/RINGER
OFF  ON

➔

TALK Button and Indicator

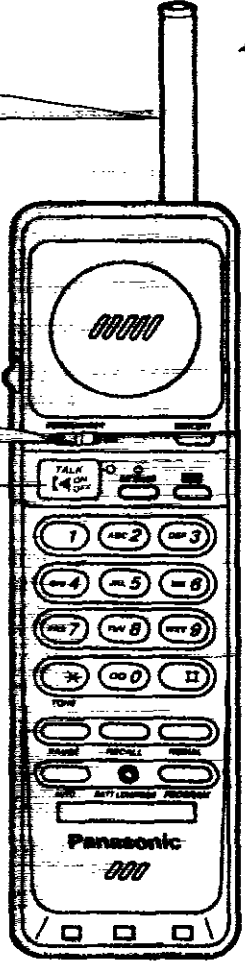

1

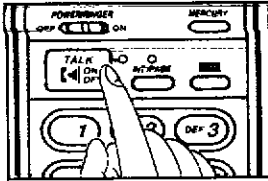

If the portable handset is off the base unit:

When the telephone rings, press the TALK button to answer the call.

– The TALK indicator light is on.

OR

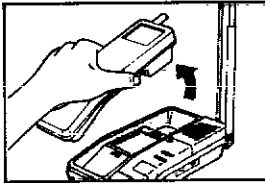

If the portable handset is on the base unit:

When the telephone rings, lift the portable handset to answer the call.

2

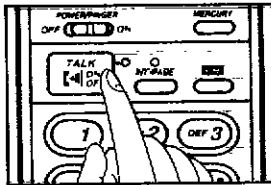

To hang up, press the TALK button or place the portable handset on the base unit.

– The TALK indicator light goes out.

Storing phone numbers in memory

The dialling buttons (0 through 9) function as memory stations for automatic dialling. A 16-digit phone number can be stored in each station.

1

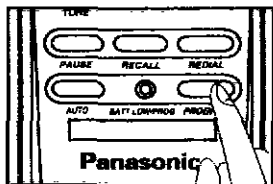

Press the PROGRAM button to switch the unit to the programming mode.

- The BATT LOW/PROG indicator light is on.

2

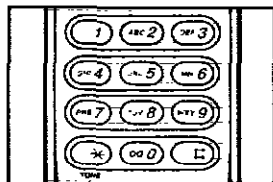

Enter a phone number up to 16 digits.

3

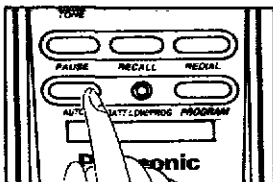

Press the AUTO button.

4

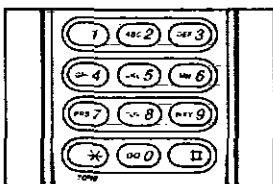

Press one of the dialling buttons (0 through 9) to select a memory station.

- The BATT LOW/ PROG indicator light goes out.
- The phone number is stored in that memory location.
- To store other numbers, repeat steps 1 through 4.

To correct an error while storing

Press the PROGRAM button to end the programming mode, then start from step 1 on page 23 to store the correct number.

To confirm a stored number

Store the phone number in the same memory station as the phone number you want to confirm. You will hear one or two beeps.

2 beeps: The newly stored number is the same as the previously stored one.

1 beep: The newly stored number is different from the previously stored one.

To erase a stored number

1. Press the PROGRAM button.
2. Press the AUTO button.
3. Press the dialling button of the memory station for the phone number to be erased.

Memory card

Pull out the memory card and write down the names or phone numbers associated with automatic dialling.

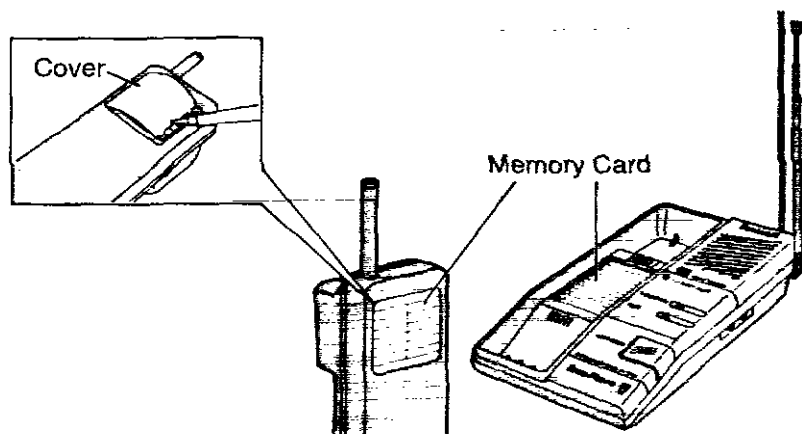

Dialling a stored number from memory

1

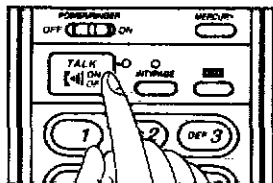

Press the TALK button to get dial tone.

– The TALK indicator light is on.

2

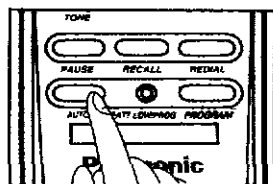

Press the AUTO button.

3

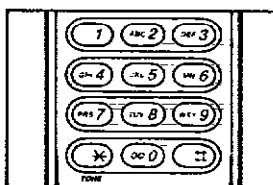

Press the dialling button (0 through 9) where the phone number you want to dial is stored.

– The stored number is dialled automatically.

Intercom between the base unit and the portable handset

You can use the portable handset and the base unit as a 2-way intercom.

Intercom mode can be maintained up to about 3 minutes. When the time-out comes near, the alarm tone sounds. Then the intercom mode is terminated forcibly. Be sure to finish the intercom mode before 3 minutes are up, or the facility of paging and intercom will be inoperable within 1 minute of the time-out.

Paging the portable handset from the base unit

1

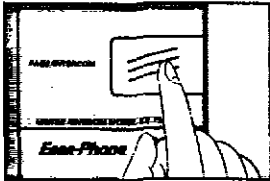

The base unit user:

Press the PAGE/INTERCOM button.

- Both units beep until the portable handset user answers the page. If there is no answer, press the PAGE/INTERCOM button again to stop paging.

2

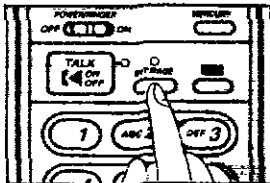

The portable handset user:

When the unit beeps and the INT/PAGE indicator flashes, press the INT/PAGE button to answer the page.

3

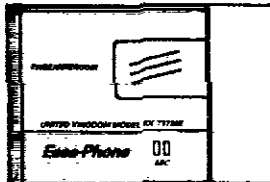

The base unit user:

Speak to the paged party through the MIC (microphone).

4

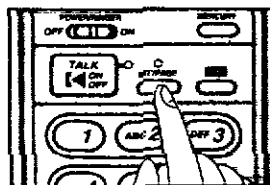

The portable handset user:

When your conversation is over, press the INT/PAGE button.

- Intercom calls can only be terminated by the portable handset.

Paging the base unit from the portable handset

1

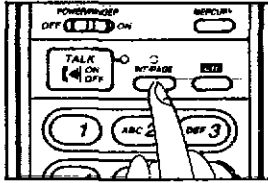

The portable handset user:
Press the INT'/PAGE button.

- Both units beep while the INT'/PAGE button is pressed. When you release it, the unit automatically switches to the intercom mode. If there is no answer, press the INT'/PAGE button again to end the intercom.

2

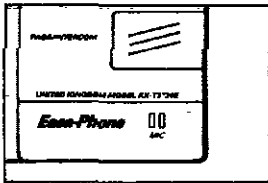

The base unit user:

When the unit beeps and the paging party's voice is heard, answer through the MIC.

3

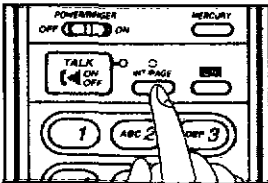

The portable handset user:

When your conversation is over, press the INT'/PAGE button.

- Intercom calls can only be terminated by the portable handset.

Helpful hints:

- Even while in a conversation with an outside caller, the portable handset user can page the base unit user by pressing the INT'/PAGE button. The outside call is put on hold then. To return to the outside call, press the TALK button.
- If you hear two tones during an intercom conversation, it means someone is calling from outside. These two tones replace the normal ringing signal. You can answer the call by pressing the TALK button. The intercom call is then terminated.

The Mercury Residential Service

Mercury's Residential Service is a highly competitive telephone service for the residential and small business user.

Most UK long distance and international calls are cheaper over Mercury, especially in the Economy period.

Mercury calls are rounded to the second, and charged to the nearest tenth of a penny. You will also receive fully itemized bills. Mercury Customer Assistance is available 24 hours a day to provide the highest level of customer service.

There are two ways to access Mercury, the Residential 132 Service and the 2300 Service. You can find out the best method for you by calling Mercury Customer Assistance on FreeCall 0500-500 194 (24 hours). Most homes and businesses are now able to access the Mercury network via their existing BT line. Mercury Customer Assistance will be able to check whether Mercury is available in your area.

All Mercury's charges and tariffs are the same for both methods of accessing Mercury—the only difference is how you connect to the Mercury network.

For Residential 132 Service customers

Once you have become a Mercury Residential 132 customer, you simply dial 132 before a long distance or international call to send it over the Mercury network.

The MERCURY button on your unit comes with the digits "132" pre-stored in it.

To check that you have access to Mercury, press the TALK button, wait for the dial tone, press the MERCURY button, and dial 132. This call is free of charge. You should be connected to a recorded message welcoming you to the Mercury network. If you have any difficulties, please contact Mercury Customer Assistance (Fault Reporting) on FreeCall 0500-500 193 (24 hours).

To send your long distance and international calls over Mercury, press the MERCURY button before the STD code and telephone number of the person you are calling.

Making a call via Mercury

1

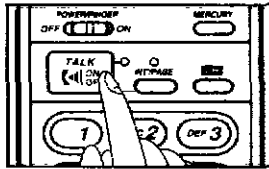

Press the TALK button.

2

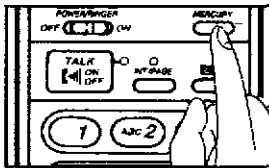

Press the MERCURY button.

3

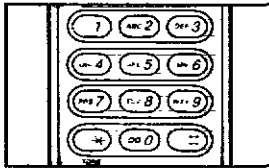

Dial the chosen Cost Centre Code* if applicable (see below).

4

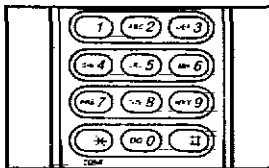

Dial either the phone number required, or automatic dial memory.

Please note that Cost Centre Codes are not currently available with Residential 132 Service.

For Residential 2300 Service customers

After you apply for Mercury's 2300 Service you will receive a Mercury PIN code in two separate parts.

The PIN code, which is similar to a bank PIN number, identifies you as a Mercury customer and will need to be stored in the unit's memory using the MERCURY button.

Programming the MERCURY button

Before programming your unit with the Mercury PIN code:

- 1) You must ascertain which type of local BT exchange you are connected to (see page 17).
- 2) Reset the Mercury station's memory (see page 34).

Ensure that the unit is plugged into the BT socket.

1

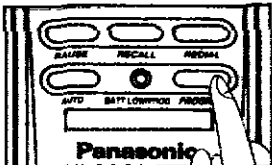

Press the PROGRAM button to switch the unit to the programming mode.

- The BATT LOW/PROG indicator light is on.

The diagram shows a hand pressing the PROGRAM button on a Panasonic control panel. The panel includes buttons for CALLER, RECALL, REDIAL, AUTO, BATT LOW/PROG, and PROGRAM. A small indicator light is visible between the BATT LOW/PROG and PROGRAM buttons.

2

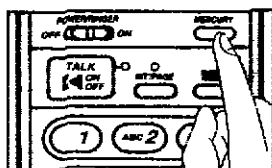

Press the MERCURY button.

The diagram shows a hand pressing the MERCURY button on a Panasonic control panel. The panel includes buttons for POWER/SLEEP, TALK ON/OFF, INTERCOM, and MERCURY. There are also buttons labeled 1, ABC 2, and DEF 3.

3

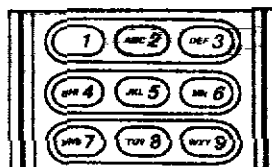

Dial 131.

The diagram shows a numeric keypad on a Panasonic control panel. The buttons are arranged in a 3x3 grid: 1, ABC 2, DEF 3; GHI 4, JKL 5, MNO 6; PQR 7, TUV 8, WXYZ 9.

4

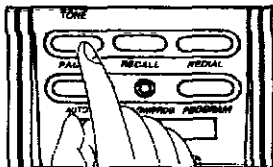

If you are connected to a **Tone exchange**;
 Press the PAUSE button once
 (twice if programming proves unsuccessful).

OR

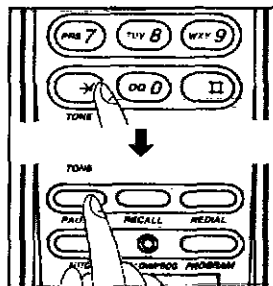

If you are connected to a **Pulse exchange**;
 Press the * (TONE) button, then
 press the PAUSE button once.

5

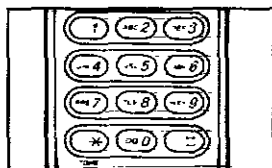

Enter the digits of the Mercury PIN code (part 1 then part 2).

– To correct an error while programming, press the PROGRAM button, then proceed from step 1 again.

6

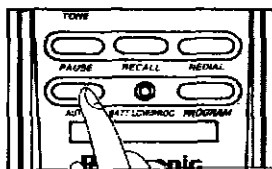

Press the AUTO button to store the program into memory.

To check if the PIN code has been programmed correctly, press the TALK button, wait for the dialling tone, and press the MERCURY button (followed by 2 or 3 digit Cost Centre Code* if applicable) and dial 1500. This call is free of charge. During connection you will hear a high pitched tone. This is the Mercury dial tone. After a few seconds you should be connected to a recorded message welcoming you to the Mercury network. If you have any difficulties, please contact Mercury Customer Assistance on FreeCall 0500-500 193 (24 hours). (*Cost Centre Code: see page 33.)

Confirming the Mercury station memory

Store the Mercury code again in the Mercury station. When the AUTO button is pressed, you will hear a beep once, twice or six times for *confirmation*.

- 1 beep: A new code number has been stored in the memory.
- 2 beeps: The code number newly entered is the same as that was previously stored.
- 6 beeps: The code number newly entered is different from the one that was previously stored. If you want to store the new code number, reset the Mercury station's memory, then reprogram it (for resetting the memory, see page 34).

Making a call via Mercury

1

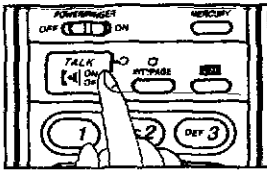

Press the TALK button.

2

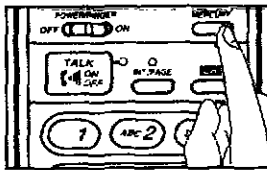

Press the MERCURY button.

3

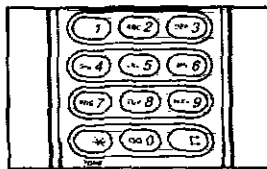

Dial the chosen Cost Centre Code* **If applicable (see below).**

4

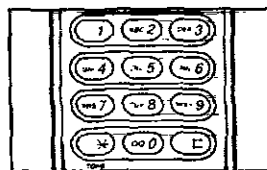

Dial either the phone number required, or automatic dial memory.

*Cost Centre Codes

Cost Centre Codes are selectable on your Mercury order form. By keying in a code number (either 2 or 3 digits) before dialling each and every Mercury call, businesses can allocate calls to different jobs, or residential users can see who is responsible for each call. If you have requested this option, then to make a call via Mercury you must:

1. Press the TALK button.
2. Press the MERCURY button.
3. Dial your chosen Cost Centre Code (any 2 or 3 digit number except 112 or 999).
4. Dial either the phone number required, or automatic dial memory.

Resetting the Mercury station's memory

(Returning to Residential 132 Service)

If you want to change your Mercury code to a new one or if you need to send your telephone away for repair, you must reset the Mercury station's memory using the following procedure.

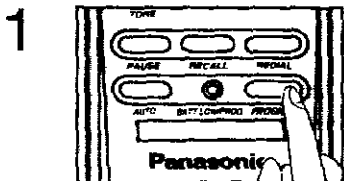

Press the PROGRAM button to switch the unit to the programming mode.

– The BATT LOW/PROG indicator light is on.

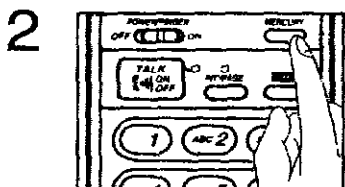

Press the MERCURY button.

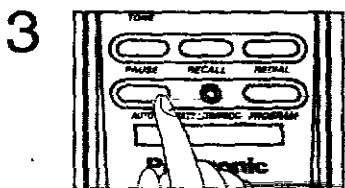

Press the AUTO button.

– The Mercury memory is reset to 132 (Residential 132 Services).
You can store a new Mercury code (see pages 30–31).

Other features

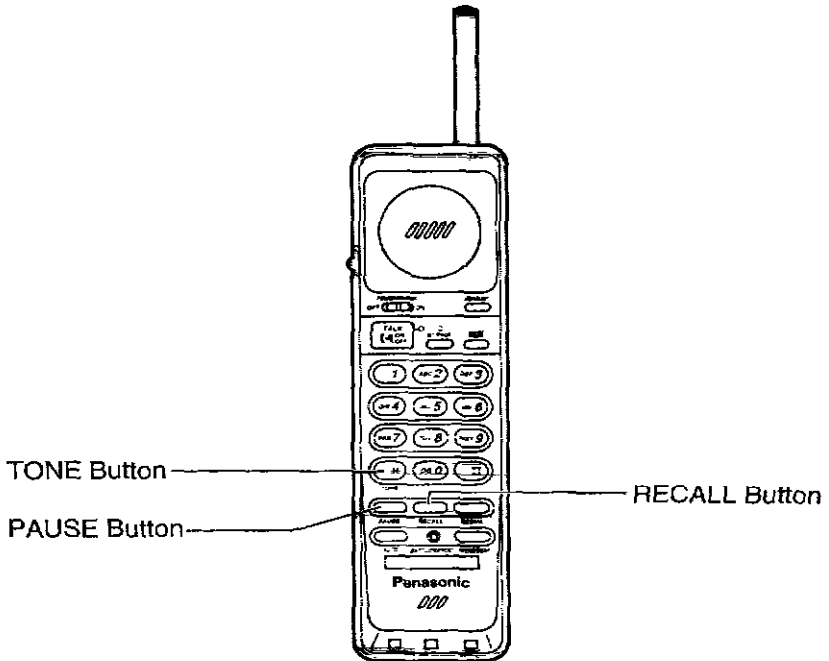

For user of a PBX (PAUSE)

If your unit is connected to a PBX, you need to dial an access number (usually 9) to get an outside line. In this case, inserting a pause between the access number and the phone number is necessary, especially when redialling or storing the number in memory. Pressing the PAUSE button once causes a 3.5-second pause.

Temporary tone dialling (TONE)

If your line has rotary service, pressing the TONE (~~*~~) button allows you to change the dialling mode temporarily into tone. Then you can dial the numbers or codes needed to operate the answering system or to use electronic banking services and other special services. When you hang up, the dialling mode returns to pulse automatically.

Using the recall feature (RECALL)

The RECALL button is used to access special telephone services (optional) such as call waiting. Contact your telephone company business office for details.

Example: British Telecom call waiting

1. Ensure that you have set the RECALL selector to the T BR position.
2. When the call waiting tone is heard during a conversation, press the RECALL button.
3. Dial 2.
The first call is put on hold and you can have a conversation with the second party.
4. **To keep the present call and return to the first call:**
Press the RECALL button, then dial 2.

To hang up the first call:

Press the RECALL button, then dial 0.

To hang up the present call and return to the first call:

Press the RECALL button, then dial 1.

If your unit is connected to a PBX, pressing the RECALL button allows you to access some features of your host PBX such as transferring an extension call.

Automatic security code setting

Whenever you place the portable handset on the base unit, the unit automatically selects one of 60,000 security codes. This code helps to avoid unauthorized use of your telephone line by another cordless telephone in your area.

Battery replacement

Replace the battery with a new one if the BATT LOW/PROG indicator flashes after a few telephone calls even when the battery has been charged for 10 hours.

1

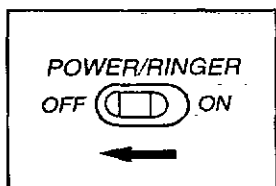

Set the POWER/RINGER switch on the portable handset to the OFF position, to prevent the memory loss.

2

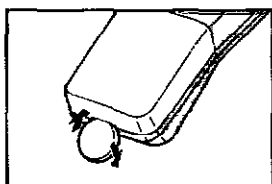

Remove the battery compartment cover using an object such as a coin.

3

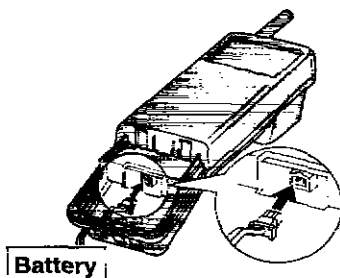

Replace the battery.

4

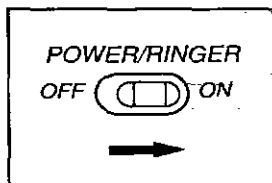

Close the cover and set the POWER/RINGER switch to the ON position.

Notes:

- Please use only Panasonic KX-A36A battery.
- Remember to charge the battery for about 10 hours after battery replacement.

Wall mounting

This unit can be mounted on a wall using screws and washers included.

- 1 Remove the handset guide from the base unit.

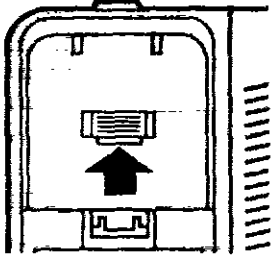

- 2 Turn the handset guide, then replace it with its tab upward.

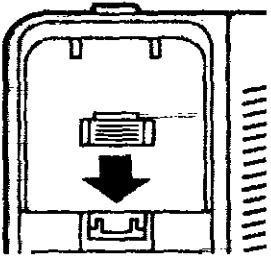

- 3 Tuck the telephone line cord inside the wall mounting adaptor.

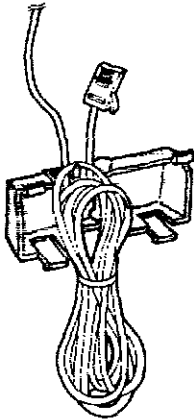

4

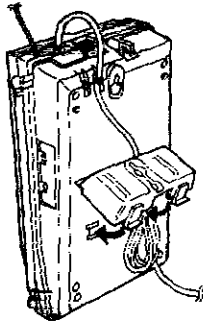

Insert the tabs of wall mounting adaptor into the openings of the unit, then push it in the direction of the arrow. (Make sure the word "UP" on the adaptor faces upward.)

5

Screws and Washers

Install screws and washers using the wall template indicated below.

Connect the telephone line cord to B.T. socket, then mount the unit securely on the screws as shown.

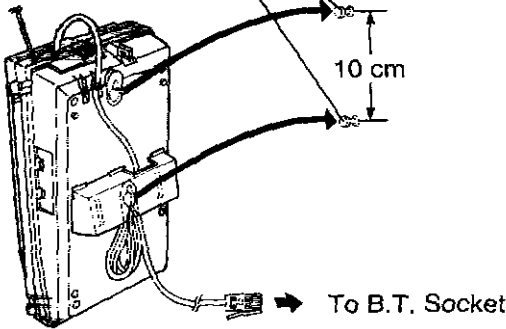

Wall Template

Drill Here

Drill Here

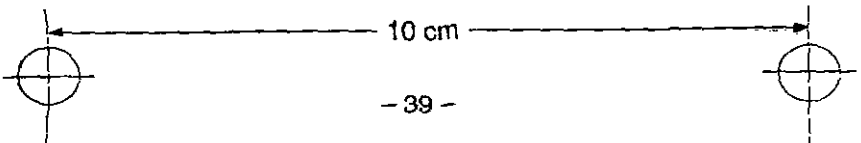

Troubleshooting guide ---

Static, sound cuts in and out, or fade. Interference from another unit.

- Electrical interference may cause static and poor range. Set the portable handset and the base unit away from other electrical appliances.
- You may be too far from the base unit. Approach it.
- Extend the aerials of the base unit and the portable handset fully (see page 8).
- Change the channel (see page 9).

When I press the TALK button to make a call, alarm tone sounds.

- Approach the base unit and try again.
- Place the portable handset on the base unit and try again.
- Make sure that the AC adaptor is connected.

I cannot store a phone number in memory.

- Do not pause for over 30 seconds while storing.
- You cannot store the number in memory while the unit is in the talk mode.

While storing a phone number, the unit starts to ring.

- You can answer the call by pressing the TALK button. The program will be cancelled, store the phone number again.

The portable handset does not operate or ring.

- The POWER/RINGER switch is in the OFF position. Set to the ON position (see page 16).

When I press the INT/PAGE button, alarm tone sounds.

- You are too far from the base unit. Approach it.

I cannot page the portable handset from the base unit.

- Paging cannot be done while the portable handset is having an outside call.
- Set the POWER/RINGER switch to the ON position.

While having an intercom call from the portable handset, two tones are heard.

- Someone is calling you from outside. To answer, press the TALK button. Intercom call is terminated.

The BATT LOW/PROG indicator flashes.

Beep tone sounds every 15 seconds during a conversation.

- Charge the battery fully (see page 7).

I charged the battery for 10 hours, but the BATT LOW/ PROG indicator flashes after a few telephone calls.

- Clean the charge contacts and charge again (see page 7).
- It is time to change the battery. Please replace with a new one (see page 37).

The unit does not work.

- The connection of the unit was made improperly (see page 12).
- The portable handset battery has become weak. Charge the battery fully (see page 7).
- The security codes in the portable handset and the base unit are not the same. Place the portable handset on the base unit.

While operating the unit, the AC adaptor feels warm.

The CHARGE indicator light never goes out while the portable handset is on the base unit.

- These are normal conditions.

I cannot use the unit during a power failure.

- The unit will not function during a power failure. We recommend that you install eight optional batteries in the Battery Box for power failure protection (see page 14).
- You can connect a reserve telephone on the same line for power failure protection (see page 15).

Safety instructions

Take special care to follow the safety suggestions listed below.

Safety

- 1) **Power Source:** The unit should be connected to a power supply only of the type described in the operating instructions or as marked on the unit.
- 2) **Non use Periods:** When the unit is not used, turn the power off. When left unused for a long period of time, the base unit should be unplugged from the household AC outlet.

Installations

Environment

- 1) **Water and Moisture:** Do not use this unit near water—for example, near a bath tub, washbowl, sink, etc. Damp basements should also be avoided.
- 2) **Heat:** The unit should be situated away from heat sources such as radiators, kitchen range, etc. It also should not be placed in rooms where the temperature is less than 5°C (41°F) or greater than 40°C (104°F).

Placement

- 1) **Stacking:** Do not place heavy objects on top of this unit.

- 2) **Foreign Material:** Care should be taken so that objects do not fall into and liquids are not spilled into the unit. Do not subject this unit to excessive smoke, dust, mechanical vibration, or shock.
- 3) **Surface:** Place the unit on a flat level surface.

For best performance

- 1) If noise prevents the conversation from being understood at the portable handset, approach the base unit to lessen the noise.
- 2) The portable handset should be used at the "HIGH" volume setting when the reception tone is difficult to hear.
- 3) The portable handset should be fully recharged on the base unit when the BATT LOW/PROG indicator flashes.
- 4) The small-sized aerial of the portable handset should not be touched during use because of its high sensitivity.
- 5) The possible calling distance may be shortened when the unit is used in the following places: Near obstacles such as hills, tunnels, undergrounds, near metal objects such as wire fences, etc.

WARNING:
TO PREVENT FIRE OR SHOCK
HAZARD, DO NOT EXPOSE
THIS PRODUCT TO RAIN OR
ANY TYPE OF MOISTURE.

STAMP
REQUIRED

Panasonic Business Systems u.k.

WILLOUGHBY RD.
BRACKNELL, BERKSHIRE
RG12 4FP

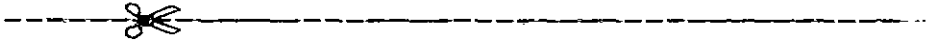

POST CARD

STAMP
REQUIRED

**The Telephone Manager
British Telecom Sales Department**

..... Area
.....
.....

MODEL No
KX-T3726E

SERIAL No

CUSTOMERS NAME etc (BLOCK CAPITALS)

DEALERS

TELEPHONE No.

DATE OF PURCHASE

WE WOULD BE GRATEFUL IF YOU WOULD COMPLETE THE FOLLOWING BEFORE RETURNING THIS CARD FOR REGISTRATION.

Male Female

Age ()

1. WHAT TYPE OF STORE?

- RADIO-TV GENERAL
- Hi-Fi/AUDIO SPECIALIST
- TELEPHONE SPECIALIST
- DEPARTMENT
- MAIL ORDER
- OTHER

2. WHEN YOU PURCHASED THIS UNIT DID YOU COMPARE WITH OTHER MODELS?

YES NO

MAKE

MODEL

PRICE

3. WHERE DO YOU PLAN TO USE?

- LIVING ROOM
- DINING ROOM
- OFFICE
- BEDROOM
- OTHER

4. HOW DID YOU LEARN OF THIS PRODUCT?

- AD. ON MAGAZINE/PAPER
- EDITORIAL IN MAGAZINE
- AD. ON HOARDING
- AD. ON TV OR RADIO
- DISPLAY IN STORE
- CATALOGUE
- OTHERS

5. WHAT PERSUADED YOU TO BUY THIS UNIT?

- TRUST IN BRAND NAME
- HIGH QUALITY
- PRICE
- DEALERS RECOMMENDATION
- FRIENDS RECOMMENDATION
- TECHNICAL SPECIFICATION
- APPEARANCE AND DESIGN
- SIMPLE CONTROLS

6. IS THIS UNIT YOUR

- FIRST OWNED?
- REPLACEMENT?

7. HOW DO YOU RATE THIS MODEL ON THE SCALE FOR:

- (a) PERFORMANCE
- (b) FEATURES
- (c) DESIGN
- (d) VALUE VS PRICE

8. IF FOR BUSINESS USE, HOW MANY EMPLOYEES ARE THERE IN YOUR COMPANY?

- UNDER 10
- UNDER 50
- 100 -

9. YOUR COMMENTS IF ANY



Registered No. 1485987

CONNECTION REQUEST

For B.T. owned wiring

The following subscriber requests you to install a wall socket to enable connection of a direct exchange line/PBX extension line for the Panasonic KX-T3726E Cordless Telephone which is fitted with a normal 431A connector

Approval Number

S/1010/3/P/502948

Subscriber

Address

Telephone Number

Signature

*Delete if not required

For wiring not owned by B.T.

Request should be made to the Authorised maintainer of the PBX for extension wiring and socket installation within 14 days. Expiry of the period or notice will allow another installer to be employed.

GUARANTEE

CONDITIONS OF GUARANTEE

This guarantee is in addition to and does not in any way affect any statutory or other rights of consumer purchasers. If within the applicable guarantee period, the appliance proves to be defective by reason of faulty design, workmanship or materials, we undertake subject to the following conditions to have the defective appliance (or any part or parts there of) repaired or replaced free of charge.

1. The appliance shall have been purchased and used solely within the UK and in accordance with standard operating instructions and the technical and/or Safety Standards required in the UK.
2. The purchaser will within 7 days of purchase complete the included card and send it to us for registration. Failure to return such card could result in delay in providing the guarantee service.
3. The appliance should be returned together with this guarantee and proof of date of purchase promptly on being found defective at the purchaser's risk and expense to the authorized dealer from whom the appliance was purchased or to the nearest authorized dealer. All enquiries must be through such dealers.
4. This guarantee shall not apply to damage caused through fire, accident, lightning, misuse, wear and tear, neglect, incorrect adjustment or repair, to damage caused through installation, adaption, modification or use in an improper manner or inconsistent with the technical and/or safety standards required in the country where this appliance is used, or to damage occurred during transit to or from the purchaser.
5. If at any time during the guarantee period any part or parts of the appliance are replaced with a part or parts not supplied or approved by us or of an objective quality safe and suitable for the appliance, or the appliance has been dismantled or repaired by any person not authorized by us, we shall have the right to terminate this guarantee in whole or in part immediately without further notice.
6. The purchaser's sole and exclusive remedy under this guarantee against us is for the repair or replacement of the appliance or any defective part or parts and no other remedy, including, but not limited to, incidental or consequential damage or loss of whatsoever nature shall be available to the purchaser.
7. This guarantee shall not apply to cassette tapes, batteries and any other items of limited natural life.
8. Our decision on all matters relating to complaints shall be final. Any appliance or defective part which has been replaced shall become our property.
9. The guarantee period applicable to this product shall be 12 months.

Please keep these Operating Instructions with your receipt.

Panasonic Business Systems U.K.

Receipt No.

Date of Purchase

Model No.

Serial No.

KX-T3726E

196

Matsushita Electric Industrial Co., Ltd.
Central P.O. Box 288, Osaka 530-91, Japan

Printed in Japan

PQQX10558ZA

S1093T1123T