

This manual describes Ericsson GF788e

Not for Commercial Use
Ericsson Mobile Communications AB

First edition (January 1998)

This manual is published by **Ericsson Mobile Communications AB**, without any warranty. Improvements and changes to this manual necessitated by typographical errors, inaccuracies of current information, or improvements to programs and/or equipment, may be made by **Ericsson Mobile Communications AB** at any time and without notice. Such changes will, however, be incorporated into new editions of this manual.

All rights reserved.

© **Ericsson Mobile Communications AB**, 1998.

Publication number: **EN/LZT 126 1433 R1A**

Printed in Sweden

INNOVATRON PATENTS

Guidelines for Safe and Efficient Use

Important: Read this information before using your portable phone

General

Since its introduction in the mid 1980s the portable phone is one of the most exciting and innovative products ever developed. With it, you can stay in contact with your office, your home, emergency services, and others.

Your telephone is a radio transmitter and receiver. When it is ON it receives and also sends out radio frequency (RF) energy. Depending upon the type of mobile phone you have purchased, it operates in different frequency ranges and employs commonly used modulation techniques. When you use your phone, the system handling your call controls the power level at which your phone transmits.

For the safe and efficient operation of your phone, observe these guidelines.

Exposure to radio frequency energy

The International Commission on Non-Ionizing Radiation Protection (ICNIRP), sponsored by the World Health Organization (WHO), published a statement in 1996 which sets limits for exposure to RF fields from handheld mobile

phone. According to this statement, which is based on the available body of research, there is no evidence that mobile terminals meeting the recommended limits can cause any adverse health effects. All Ericsson telephones conform to the ICNIRP recommendations, and international exposure standards, such as:

CENELEC European Pre-standard
ENV50166-2

ANSI/IEEE C95.1-1992 (USA, Asia-Pacific)

If you want to limit RF exposure even further, you may choose to control the duration of your calls and operate your phone in the most power efficient manner.

Efficient phone operation

How to use your phone for optimum performance with minimum power consumption:

Hold the phone as you would any other telephone. While speaking directly into the mouthpiece, angle the antenna in a direction up and over your shoulder. If the antenna is extendable, it should be extended during a call.

Do not hold the antenna when the phone is **IN USE**. Holding the antenna affects call quality,

may cause the phone to operate at a higher power level than needed and shorten talk and standby times.

Antenna care and replacement

Do not use the phone with a damaged antenna. Replace a damaged antenna immediately. Consult your manual to see if you may change the antenna yourself. If so, use only an Ericsson approved antenna. Otherwise, take your phone to a qualified service centre for repair.

Use only the designated Ericsson antenna. Unauthorized antennas, modifications, or attachments could damage the phone and may violate the appropriate regulations.

Do not use an antenna designed for any other type of portable telephone than the telephone you have purchased.

Driving

Check the laws and regulations on the use of telephones in the areas where you drive. Always obey them. Also, when using your phone while driving, please:

Give full attention to driving.

Use hands-free operation, if available.

Pull off the road and park before making or answering a call if driving conditions so require.

RF energy may affect some electronic systems in motor vehicles. In addition, some vehicle manufacturers forbid the use of mobile phones in their vehicles. Check with your vehicle manufacturer's representative to be sure your phone will not affect the electronic systems of your vehicle.

Electronic devices

Most modern electronic equipment, for example, equipment in hospitals and cars, is shielded from RF energy. However, RF energy from telephones may affect some electronic equipment.

Turn your phone OFF in health care facilities when regulations posted in the areas instruct you to do so. Always request permission before using your phone near medical equipment.

Mobile telephones may affect the operation of some implanted cardiac pacemakers, equipment for people with hearing impairments and other medically implanted equipment. Pacemaker patients should be aware that the use of a mobile phone very close to a pacemaker may cause the device to malfunction. Avoid placing the phone over the pacemaker, i.e. in your breast pocket. When using the phone, place it at your ear opposite the pacemaker. If a distance of 15cm. is kept between the phone and the pacemaker, the

risk of interference is limited. Contact your cardiologist for more information.

Aircraft

Turn your phone OFF before boarding any aircraft.

Use it on the ground only with crew permission

Turn off your phone before the aircraft leaves the ground. Do not use it in the air.

To prevent possible interference with aircraft systems, safety regulations require you to have permission from a crew member to use your phone while the plane is on the ground. To prevent interference with communication systems, you must not use your phone while the plane is in the air.

Power Supply

Connect AC (Power supply) only to designated power sources as marked on the product.

To reduce risk of damage to electric cord, remove from outlet by holding onto AC adapter rather than cord.

Make sure the cord is located so that it will not be stepped on, tripped over or otherwise subjected to damage or stress.

To reduce risk of electric shock, unplug unit from power source before attempting any cleaning, then use soft cloth dampened on with water.

Children

Do not allow children to play with your phone. It is not a toy. Children could hurt themselves or others (by poking themselves or others in the eye with the antenna for example). Children could also damage the phone or make calls that increase your telephone bills.

Blasting areas

To avoid interfering with blasting operations, turn your unit OFF when in a "blasting area" or in areas posted "turn off two-way radio". Construction crews often use remote control RF devices to set off explosives.

Potentially explosive atmospheres

Turn your phone OFF when in any area with a potentially explosive atmosphere. It is rare, but your phone or its accessories could generate sparks. Sparks in such areas could cause an explosion or fire resulting in bodily injury or even death.

Areas with a potentially explosive atmosphere are often, but not always, clearly marked. They include fuelling areas, such as gas stations, below deck on boats, fuel or chemical transfer or storage facilities, and areas where the air contains chemicals or particles, such as grain, dust, or metal powders.

Do not transport or store flammable gas, liquid, or explosives in the compartment of your vehicle which contains your phone and accessories.

Product care

Do not expose product to water or moisture. Example: bathtub, laundry sink, wet/damp basement, swimming pools, etc.

Do not expose product to extreme temperatures such as found near a hot radiator or stove, or in a car parked in the sun.

Do not expose product to extreme cold temperatures such as a car parked outdoors in winter

Do not expose product to lit candles, cigarettes, cigars, open flames, etc.

Use only Ericsson Original accessories. Failure to do so may result in loss of performance, fire, electric shock, or injury, and will void the warranty.

Do not attempt to disassemble the product. Doing so will void warranty. This product does not contain consumer serviceable components. Service should only be performed by Authorized Service Centres.



The **CE** symbol on our products signifies that they have been certified according to the EMC directive 89/336/EEC, the Telecommunications directive 91/263/EEC, and the Low Voltage directive 73/23/EEC when applicable. The products fulfil the requirements according to the following standards:

Cellular Phones and Accessories in Combination: ETS 300 342-1 EMC for European digital cellular telecommunications.

Accessories Without Direct Connection to a Cellular Phone: EN 50081 Electromagnetic compatibility, Generic Emission Standard, and EN 50082 Electromagnetic compatibility, Generic Immunity Standard.

Not for Commercial Use
Ericsson Mobile Communications AB

Table of Contents

Guidelines for Safe and Efficient Use

Assembly Instructions

Assemble and Charge – Four Steps

1. Inserting SIM Card

2. Attaching Battery

3. Connecting

Charger to Phone

4. Connecting

Charger to Mains

The Charging

Function

The Battery

and the SIM Card

Turning On the Phone and General Information

Turning On

the Phone

Learning about

Your Phone

Making and Receiving Calls

Making a Call

Ending a Call

Making an

International Call

Making an

Emergency Call

Retry Function

i	Receiving a Call	7	Storing Numbers on SIM Card	12
1	Answering a Call	7	Storing Numbers in Phone Memory	12
1	Rejecting a Call	8	Entering Letters	13
1	Putting a Call on Hold	8	Recalling Phone Numbers	13
1	Calling Line Identification (CLI)	8	Position Recall	13
1	Handling Two Calls	8	Changing Phone Book Entry	14
2	Conference Calls	9	Last Dialed Numbers	14
2	Transferring Calls	9	Unanswered Calls	14
2	Line 2 Option	9		
2	Useful Information while Talking	10	Personalizing Your Phone	15
3	Changing Volume while Talking	10	Changing Ring Volume	15
3	Using Phone as Scratch Pad	10	Changing Earpiece Volume	15
3	Sending Tone Signals	10	Ring Type	15
3	Checking Time or Cost of Calls	10	Viewing the Clock	15
4	Navigating the Menu System	11	Setting Clock	15
4	About the Menu System	11	Setting Alarm	15
6	Moving Through the Menu System	11	Turning Off the Alarm	16
7	Selecting the Extended Menus	11	Display Language	16
7	Creating Your Own Phone Book	12	Answering Modes	16
7	The Phone Book	12	Handsfree Types	16
7			Greeting	16
7			Call Waiting	16
7			Call Information	17
7			Changing Key Sound	17
7			Choosing Message Signal	17

Making Your Personal Ring Signal	18	Customizing Your Reduced Menu	24	Knowing Cost and Duration of Calls	28
Phone Note System	18	Customizing Menus	24	Call Time	28
Simple Melody	18	Adding Menus	24	Call Cost	28
Diverting Calls	19	Changing Menu Position	24	Specific Data Menus	29
Diverting Calls	19	Deleting Menus	24	Having Data Menus On	29
Diverting from Reduced Menu	19	Resetting Menus to Original	24	Diverting Fax and Data Calls	29
Diverting from Extended Menu	19	Sending and Receiving Text Messages	25	Other Networks	30
Viewing Status of Call Divert	20	Text Messages	25	Choosing Network	30
Cancelling Call Divert	20	Checking Subscription	25	Selecting a Network	30
Protecting Your Keypad, Phone and SIM Card	21	Setting Service Centre Address	25	Index	31
Locks	21	Sending SMS	25		
Keypad Lock	21	Other Message Types	25		
Card Lock (SIM)	21	Receiving a Message	26		
Changing PIN	21	Reading an Old Message	26		
Unblocking with PUK	21	Receiving Area Information	27		
Phone Lock	21	Area Information	27		
(Un)Locking Phone	22	Activating the Area Information	27		
Barring Calls – Restricting Calls	23	Adding a Code	27		
Barring Calls	23	Erasing a Code	27		
Activating Call Bars for Any Call Type	23	Changing a Code	27		
Cancelling All Call Bars	23				

Assembly Instructions

Assemble and Charge – Four Steps

- Insert the SIM Card.
- Attach the battery.
- Connect the charger to the phone.
- Connect the charger to the mains.

1. Inserting SIM Card

Place the SIM Card with the golden connectors facing down and the cut corner turned to the left (see Figure 1).

Slide the SIM Card into the SIM Card slot.

The SIM release button slides towards the antenna as you push in the SIM Card.

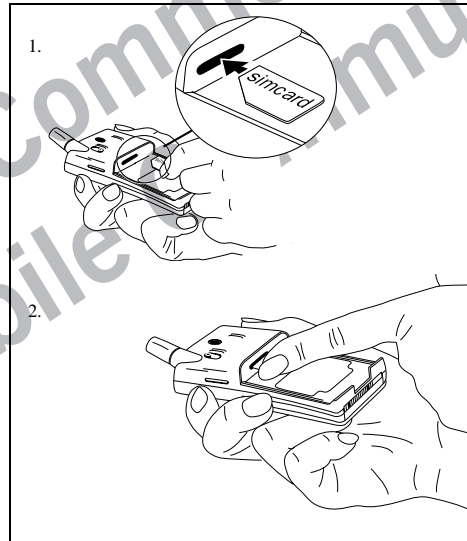

Figure 1. Inserting SIM Card

Removing SIM Card

1. Make sure the battery is removed.
2. Slide the SIM release button towards you (see Figure 2).
3. Pull out the SIM Card.

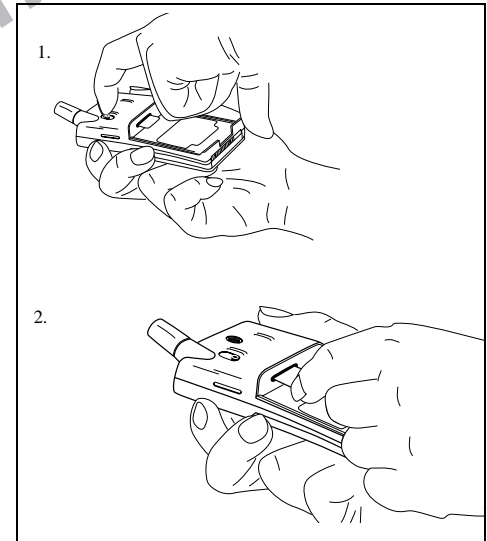

Figure 2. Removing SIM Card

2. Attaching Battery

Place the battery on top of the phone. Push until you hear a click (see Figure 3).

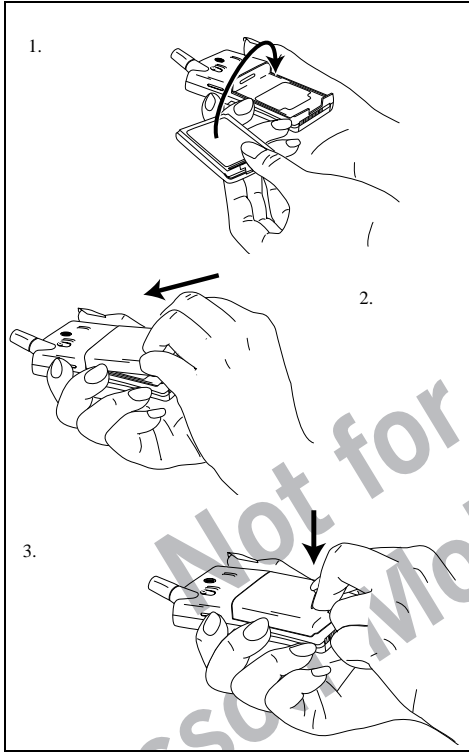

Figure 3. Attaching battery

Removing Battery

1. Make sure the phone is turned off.
2. Press the catch on the bottom of the battery (see Figure 4.).
3. Lift the battery up and away from the phone.

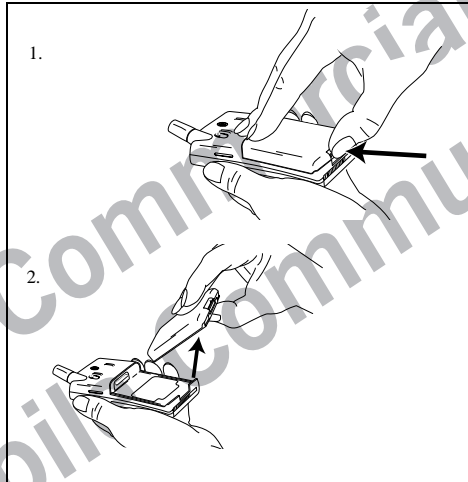

Figure 4. Removing battery

3. Connecting Charger to Phone

Have the battery attached to the phone and connect the charger as described in Figure 5. Use the power plug that fits your mains.

Disconnecting Charger

Lift the plug up and pull it out (see Figure 5).

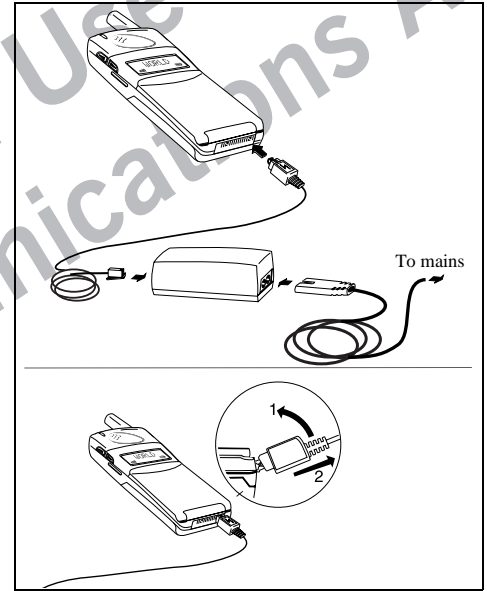

Figure 5. Connecting and disconnecting charger

4. Connecting Charger to Mains

Plug the charger into a mains socket. The battery starts charging. You can see the battery meter in the display move while charging.

The Charging Function

When you connect external power to the phone, the battery starts charging. When the battery is fully charged, the charging stops. You cannot overcharge your battery.

When you are charging the battery, you can use your phone as normal, but the charging time will be longer.

The Battery and the SIM Card

The Battery

Your phone is supplied with a Nickel Metal Hydride battery. The battery is not charged before shipment, even though there might be enough power to turn the phone on.

The SIM Card

Before you can start using your phone, you need to order a SIM Card from a GSM service provider. The SIM Card keeps track of your

phone number, the services that you order from the service provider and your phone book information.

Your SIM Card is supplied with a security code or PIN (Personal Identity Number). You must enter this into the phone to gain access to the phone and network.

Note!

Some services described in this manual may not be available in all networks. Please, see your service provider for more information.

Turning On the Phone and General Information

Turning On the Phone

1. Press and hold down the **NO** key until you hear a click. The display prompts you to enter your PIN (the security code that follows your SIM Card).

PIN:

2. Enter the PIN and press **YES**.
The PIN is indicated as **** in the display.

If you entered the PIN correctly, you will be welcomed by your phone. Then it searches for a network.

When your phone finds a network, the indicator light on the top of the phone flashes green once every second.

The standby display is shown (see Figure 6).



Figure 6. Standby display

Turning Off the Phone

- Press and hold down the **NO** key until you hear a click and the display turns dark.

The Display

Your phone display helps you to:

- Make sure that you are dialling correctly.
- Check your battery status.
- Check your signal strength and service availability.
- Indicate that you have received messages.

Looking at the Display

The picture below shows what the display looks like when the entire icon row is lit. Table 1 explains what each icon means.



Figure 7. Display with all icons lit

Note!

All icons may not be visible at all times.

Table 1. Description of display icons.

Icon:	Indicates:
WORLD	Network The name and country of the network.
	Signal Strength The received signal strength in five steps.
L1 L2	Line Whether line 1 or 2 is active. These icons only show if you have two lines on your SIM Card.
	Divert That the phone has a divert active. The arrows corresponds to the diverted line.
	Silent Ring Signal That no ring signal sounds when the phone is rings.
	Letter That you have received a short text message or area information.
	Phone That you are engaged in a call.
	Battery The current battery strength – more bars there are the more power there is.

Learning about Your Phone

The parts list corresponds to Figures 8 and 9:

1. Antenna
2. Status light
3. Earpiece
4. Volume keys
5. Display
6. Keypad
7. Microphone (inside)
8. Flip
9. Microphone channel
10. Charging connector
11. Battery
12. SIM release button
13. Phone clip holder

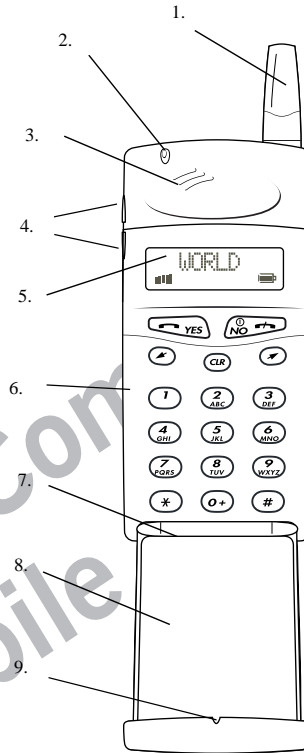

Figure 8. Front view of your phone

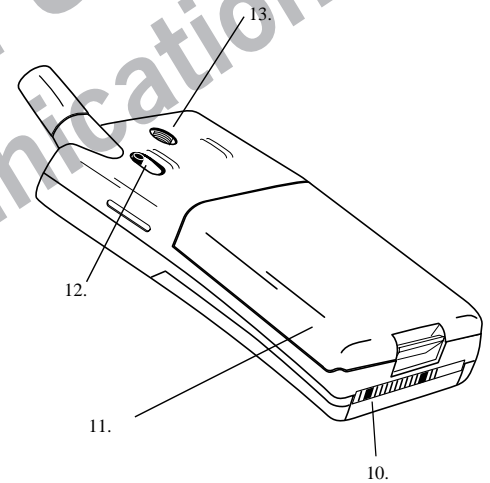

Figure 9. Rear view of your phone

Making and Receiving Calls

Making a Call

1. Enter the area code and phone number.
The phone number appears in the display. If the number is longer than 10 digits, the beginning of the number is shown as an arrow (see Figure 10).



Figure 10. Number with more than 10 digits

To erase a digit, press **CLR**. To erase the entire phone number, press and hold down **CLR** for a couple of seconds.

2. Press **YES** to make the call. The display shows **Calling**, followed by **Connecting**. The phone icon appears.
If the number is busy, you hear a busy tone and the display shows **Busy**.

Holding the Phone

Put the earpiece to your ear for the best speech and reception quality (see Figure 11).



Figure 11. Holding your phone

Ending a Call

- Press **NO** to end the call.

Making an International Call

1. Press and hold the zero key until the international + sign is displayed.
2. Enter the country code, area code (without any leading zero) and the phone number.
3. Press **YES** to make the call.

Making an Emergency Call

- Enter **112** (the international emergency number) and press **YES**. The display shows **Emergency**.

The **112** emergency number can be used in any country with or without a SIM Card, if a GSM network is within range.

Note!

Some GSM networks do not support the international emergency number.

Retry Function

If the call connection fails, the display shows **Retry?** Press **YES** to redial the number, otherwise **NO**.

Receiving a Call

When you receive a call, the phone rings and the indicator light on the top of the phone blinks green rapidly. The display shows **Answer?**

Answering a Call

- Press **YES** to answer the call
- When the call is finished, press **NO**.

Rejecting a Call

- Press **NO** or a volume key twice when the phone rings.

The display now looks like this:

BusyTone

If the caller's network supports it, the caller hears a busy tone.

If you have been unable to answer, or you have rejected a call, the number of the unanswered call is shown in the display until you press **CLR** (this depends on your subscription).

Putting a Call on Hold

If you are engaged in a call, you can put it on hold by pressing **YES**. This mutes the microphone so that you can have a private conversation without the person at the other end hearing. To put the call **off hold**, press **YES** again.

Calling Line Identification (CLI)

The Calling Line Identification service shows the caller's phone number when you receive a call (you have to order this service). If the caller's name is stored in your phone book, the name is displayed instead of the number.

Showing Your Phone Number

If you subscribe to **withhold** your number when calling, you can show the number on a particular call.

1. Enter the number you wish to call.
2. Press **↖**.
The display shows **Send Id?**
3. Press **YES** to make the call.

Hiding Your Phone Number

If you subscribe to **show** your number when calling, you can hide your number on a particular call.

1. Enter the number you wish to call.
2. Press **↖** twice.
The display shows **Hide Id?**
3. Press **YES** to make the call.

Handling Two Calls

Your phone can handle two calls simultaneously. This allows you to hold one call and make or receive another. You can switch between the two calls.

To receive a second call, you must activate the Call Wait function (see the chapter on *Personalizing Your Phone* on page 12).

Receiving a Second Call While a Call Is in Progress

When you receive a second call, you will hear a tone in the ear piece and the display shows **Call Wait**.

- Press **YES** answer the second call. The current call is put on hold.
The display now looks like this.

1 On Hold

- To **reject** the second call, press zero followed by **YES**.

Switching Between Two Calls

- Press **YES** to switch between the two calls.

Ending the Current Call and Return to the Held Call

1. Press **NO** to end the current call.
The display shows **Retrieve?** and you hear two beeps.
2. Press **YES** within three seconds to return to the held call.

If you do not press **YES** within three seconds, the held call is ended automatically.

Making a Second Call while a Call Is in Progress

- Enter the second phone number and press **YES**. The first call is put on hold and the display looks like this:

1 On Hold

Receiving a Third Call

If you are engaged in one call and have a second one on hold, you may receive a third call. You hear a tone in the ear piece and **CallWait** is shown in the display.

You can only have one call on hold at a time, so you need to end the first or second call before you answer the third one.

You can do one of the following:

- Press zero and then **YES** to reject the third call.
- End the first call, retrieve the held call, and answer the incoming call.
- End both calls. The phone rings and the question **Answer?** appears in the display. Press **YES** to answer the call.

Conference Calls

The conference call service allows you to have a joint conversation with up to five people. You

may put an individual or a group or conference members on hold while you add other people to the conference call. You may also put conference members on hold while you talk to someone privately.

The Conference Call service may not be available in all networks. Contact your operator to find out whether your network supports it.

Initiating a Conference Call

1. Call the first person you wish to include in the conference call.
2. Put this person on hold by pressing **YES**.
3. Call the second person you wish to include in the conference call.
4. Press **3**, then **YES** to include the two people in the conference.

You can put the conference group on hold and then add a third member by repeating steps 2 to 4. It is possible to add up to five members in this way.

Transferring Calls

If you have one active call and another call on hold, you can connect the two by pressing **4**,

then **YES**. You are then disconnected from both calls.

Line 2 Option

Your phone can support two phone lines if your service provider offers this service. Having two different phone numbers on the same SIM Card makes it easy to keep business and private calls separate.

When you receive a call, the display shows **Answer?** After that it toggles between **L1?** (or **L2?**) and the caller's number.

When you want to make a call, you choose the phone line by toggling between **L1** and **L2**).

- To toggle between **L1** and **L2**, press the right arrow key then **YES**.

Divert L1 and L2

When a second line is introduced, **Line 2** is added to the menu structure and the **Divert** menu splits into **Divert L1** and **Divert L2** so that you will be able to divert each line separately (see *Chapter Diverting Calls* on page 19). You can divert Line 1 to an answering machine, for instance, and keep Line 2 active.

Useful Information while Talking

Changing Volume while Talking

During a call, you can use the volume keys to increase or decrease the earpiece volume (see Figure 12).

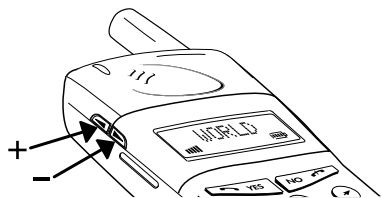

Figure 12. Changing volume

Using Phone as Scratch Pad

1. Enter a phone number on the keypad while talking.
When you end the call, the number remains in the display.
2. Press YES to make the call in the display.

Sending Tone Signals

During a call you can press keys 0–9, * and # to send DTMF tones. For example, to use telephone banking services or to control an answering machine.

Checking Time or Cost of Calls

When you start a call (incoming or outgoing), the airtime is counted in minutes and seconds and shown in the display like this:

1:34

If you want the phone to keep track of the costs you need to set that specifically. Check if your service provider supports this service (see chapter *Knowing Price and Duration of Calls* on page 28).

Navigating the Menu System

About the Menu System

You control the functions of your phone by a menu system. There are two sizes:

- Reduced
- Extended

In this manual package, there is a separate leaflet which describes all the original settings of both the reduced and extended menu system.

Hint!

When you go through this manual, have the leaflet with all menus handy at the same time.

Some menus have sub-menus that have individual settings. If the menu has sub-menus, three dots appear after the menu name. See the example below:

Settings...

The Reduced Menus

The reduced menu consists of those functions and settings you probably use most. This menu system can be personalized to fit your specific needs. When you personalize the system, you

move menus and sub-menus from the extended menu system to the reduced.

You learn how to personalize your menus in *Customizing Your Reduced Menu System* on page 24.

The Extended Menus

The extended menu contains all the functions and settings available from the phone.

Moving Through the Menu System

Use these keys to move through the menu system and to find the different menus.



When you reach the desired menu, press **YES** to choose the menu. Use the **↔**/**↵** keys until you reach the function or setting you want. Then, in the same way you chose a menu, press **YES** to select the setting or function.

Press:	To:
YES	confirm a setting or a selection.
NO	reject a setting or a function.
CLR	return to the standby display.
↵	scroll to the right in the menu system.
↶	scroll to the left in the menu system.

Glossary

These terms will be used throughout the manual:

- Scroll:** Press the left or right arrow key to move between the menus.
- Select:** Scroll to a menu and then press **YES**.
- Enter:** Key in letters or numbers from the keypad.

Selecting the Extended Menus

1. Press **CLR** to clear the display.
Press the left arrow key four times until you reach the **Menu Size** menu.
2. Press **YES**.
You are now in the **Menu Size** menu where you can switch to the Extended menu mode.
3. Press **YES** at the Extend prompt.

Creating Your Own Phone Book

The Phone Book

You can store phone numbers in two places: on your SIM Card and in your phone's own memory. The choice is based on your needs. If you use one SIM Card in many phones, the phone book stored on the SIM Card is always available to you. If you have one telephone and use several SIM Cards, the phone's phone book is always available to you.

You can store up to 99 phone numbers in the phone memory. SIM Card capacities vary.

International Numbers

If you intend to use your phone book both at home and abroad, you should store all phone numbers as international phone numbers, i.e. with the international (+) sign and the country code before the area code (without any leading zero) and the number.

- To enter the (+) sign, press and hold **0** (zero) until you see + in the display.

Speed Dialling

The phone numbers that you store in positions 1-9 on the SIM Card can be called by entering the position number and then pressing **YES**. You should, therefore, save positions 1-9 for important numbers.

Storing Numbers on SIM Card

1. Select the **Store** menu (second to the left from standby) by pressing **YES**.
2. If you don't have the right phone number in the display from the start, clear the display and enter it now.
3. Press **YES**. The display shows **Name**:
4. Enter the first letter of the name by tapping the key with the appropriate letter. If it is the second letter, you need to tap the key twice to produce it (see *Entering Letters*). Wait for the cursor to move to the right before entering the next letter. The number of characters allocated for each name vary with SIM Cards. Press **YES** when you have keyed in the name. The display shows **POS:** and a number. This is the first available position on the SIM Card.
5. If you want the storage position suggested in the display, press **YES** (see step 6). If you want to store the number in a different position, press **CLR** to erase the suggested position number and enter another number. If you choose a position number that is already occupied, **Overwrite?** is displayed. Press **YES** to

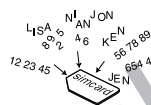



overwrite or **NO** to return to the position number and change it.

6. Press **YES** to confirm the position number. The display briefly shows **Stored**. The listing has been saved. The display changes to **Store**. You are back to the **Store** menu and can now enter another phone number.

Storing Numbers in Phone Memory



Follow the same procedure as for storing phone numbers on SIM Card, up to step 5. This is where you are prompted to accept or reject a storage position number. The suggested number is for a SIM Card position, if there is one available. Otherwise the phone suggests a position in the Phone memory. Clear the number by pressing **CLR**. Access the phone memory by pressing **#**. The symbol  appears in the display. Press **#** again. The symbol  is now followed by a number which represents the first available position in the phone memory. Confirm by pressing **YES** or change the digit.

Entering Letters

You can enter letters and other characters using the keypad:

Press the appropriate key, **1-9, 0** or **#** repeatedly until the desired letter, character or digit appears in the display. For example, to enter an A, press number key 2. To enter B, press number key 2 twice.

- 1 Space - ?! , . : ‘ ’ () 1
- 2 A B C Å Ä Æ à ç 2 G
- 3 D E F è È 3 D F
- 4 G H I ì 4
- 5 J K L 5 L
- 6 M N O Ñ Ö Ø ò 6
- 7 P Q R S b 7 P S
- 8 T U V Ü ù 8
- 9 W X Y Z 9
- 0 0 + & @ / \$ % £ Q X Y W
- # # *

Note!

In the letter mode, you can still enter digits but they are positioned deep. Hold down the key until the digit appears in the display instead of tapping.

Entering Lower Case Letters

Enter the letter A for example and then press *. The capital A is replaced by a lower case a. All letters will now be lower case until you press * again.

Note!

Pressing one of the volume keys together with a number key, will get you to the second or third letter position directly.

To exit the letter mode and return to standby, clear the display, by pressing CLR. Then press CLR again.

Recalling Phone Numbers

You can recall a phone number any time from either the SIM Card or the phone memory. You can recall the phone number either by the name or the storage position number.

Recalling by Name

1. Press CLR to erase any digits from the display.
2. Select the **RecallName** menu.
You are prompted to enter a name.
3. Enter either the full name or the first letter and press YES.
The first name that matches the letter is displayed. If necessary, scroll to the name you want.

The selected name and number flash in the display until you press the * key.

4. Press YES to call the number.

Recalling by Number – Speed Dialling

1. Press CLR to erase any digits from the display.
2. Enter a position number between 1 and 9.
3. Press YES to make the call.

Position Recall

From SIM Card

1. Enter the position number and press #.
 2. Press YES to call the number, or scroll until you find the number you want to call and press YES.
- Press CLR to return to the standby display with the number showing.
 - Press NO to return to the standby display.

From Phone Memory

1. Press and hold # until the ☐ symbol appears.
2. Enter the position number.
3. Press # to recall number.
4. Press YES to call the number, or scroll until you find the number you want to call and press YES.

Changing Phone Book Entry

1. Select the **EditPhBook** menu.
2. Enter either the full name or the first letter and press **YES**.
The first name that matches the letter is displayed. If necessary, scroll to the name you want and press **YES**.
3. Scroll through the name to change its letter and press **YES**.
The phone number is displayed.
4. Scroll through the phone number to change its digit by digit and press **YES**.
The position number is displayed.
5. Enter a new position number and press **YES**.
If the new position is already occupied, you will be asked to **Overwrite?** the position.

Press **YES** to confirm, and **NO** to change the position.

Deleting Storage Position

1. Select the **RecallName** menu.
2. Choose the name you want to delete, press and hold **CLR**.
3. Press **YES** at the Erase prompt.

Last Dialed Numbers

Your phone can store at least the five last numbers dialed. You may be able to store more, depending on your SIM Card.

Recalling From List of Last Dialed Numbers

1. Press **CLR** to erase any digits from the display.
2. Press **YES**. The number last called is shown.

3. Press **YES** to call the number or scroll to the number you want to call.

Unanswered Calls

Sometimes you are unable to answer a call. Then the phone keeps track of your latest missed calls in the **MissedCall** menu.

Checking Unanswered Calls

Select the **MissedCall** menu. The time of the missed call is shown.

Now do one of the following:

- Press **YES** to see who the call is from (CLI).
- Press **CLR** to erase the call.

Personalizing Your Phone

Changing Ring Volume

1. Select the **Ring Vol** menu.
2. Scroll to the desired ring volume, press **YES**.
Use the volume keys to scroll silently.

Turning Off Ring Volume

1. Select the **Ring Vol** menu.
2. Press the left arrow key until no squares are lit and press **YES**.

The standby display now looks like this:



Changing Earpiece Volume

1. Select **Ear Volume** in the **Settings** menu.
The display now looks like this:

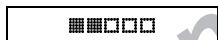

2. Press the the right arrow to increase the volume or the left arrow to decrease the volume.
3. Press **YES** when you are finished.

Ring Type

You can choose between different types of ring signals. You can also choose a melody that you have created yourself (see the chapter on *Making Your Personal Ring Signal* on page 18).

Changing Ring Type

1. Select **Ring Type** in the **Settings** menu.

The display now looks like this.



2. Press the right or left arrow to listen to the different ring types. Use the volume keys to scroll silently.
3. Press **YES** to select your preferred ring type.

Viewing the Clock

If you want to view the time on your phone, press one of the volume keys on the side of the phone.

Setting Clock

1. Select **Set Clock** in the **Settings** menu.
The display now looks like this.

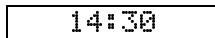

2. Enter the correct time.

3. Press **YES**.

Press * to toggle between am and pm.

Press # to toggle between 12- hours and 24- hours.

Setting Alarm

1. Select the **Set Alarm** menu.
The last alarm time is shown.

2. Enter the alarm time.

3. Press **YES**.

The standby display now looks like this:

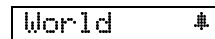

Your alarm works even when the phone is turned off.

When the Alarm Rings...

1. Press any key and the **Turn Off** prompt appears.
2. Press **YES** to turn it off completely or any key to activate the snooze function (9 minutes).

Turning Off the Alarm

1. Select the **Set Alarm** menu.
The **Off** prompt appears.
2. Press **YES**.

Display Language

Your phone has many languages to choose from for your display.

Note!

When you change language, you change all display texts **immediately**.

Changing Display Language

1. Select **Language** in the **Settings** menu.
2. Scroll to the language you want to have in your display texts.
3. Press **YES** to select the language.

Resetting Display Language to English

1. Clear the display.
2. Enter the digit string **↵0000↵**.

Answering Modes

Two additional answering modes are possible for your phone is connected to handsfree equipment. The two modes are:

Automatic: The phone answers the call automatically after two ring signals.

Any key: You answer by pressing any key, except **NO**, on the phone keypad.

Changing Answering Mode

1. Select **Answ Mode** in the **Settings** menu.
 2. Select the option you wish to have for your handsfree equipment.
- To turn off the handsfree option, choose **Off** in the **Answ Mode** sub-menu.

Handsfree Types

If you have transmission problems with your Handsfree equipment, you can try the Type 1 setting (Type 2 is default).

Type 1: Half-duplex transmission.

Type 2: Duplex transmission.

Changing Handsfree Type

1. Select **Handsfree** in the **Settings** menu.
2. Select either **Type 1** or **Type 2**.

Greeting

A greeting appears after you enter your PIN. The default greeting is: *Ericsson*. You can also turn the greeting off.

Off: No text is displayed at startup.

On: Welcome or your own message is displayed at startup.

Making Your Own Greeting

1. Select **Greetings** in the **Settings** menu
The display now looks like this.

New Text

2. Select **New Text**.
3. Enter the new text from your keypad and press **YES**.

Hello

You can have up to 10 characters in the greeting text.

Call Waiting

When activated the call waiting function allows you to handle two calls at a time. You may need to order this feature from your service provider.

To handle two calls, see the chapter on *Making and Receiving Calls* on page 6.

Activating/Deactivating Call Waiting Function

1. Select **Call Wait** in the **Settings** menu.
2. Select either **Activate** or **Cancel**.

Call Information

This function lets you present call information in either time or cost. To set the cost and time

counter (see chapter *Knowing Price and Duration of Calls* on page 28).

Activating Call Information

1. Select **Call Info** in the **Settings** menu.
2. Select the call information (cost or time) you want displayed and press **YES**.

Changing Key Sound

1. Select **Key Sound** in the **Settings** menu.
2. Select the key sound you want.

Choosing Message Signal

1. Select **Mail Alert** from the **Settings** menu.
2. Choose the sound you want to hear when you receive a text message (SMS).

Not for Commercial Use
Ericsson Mobile Communications AB

Making Your Personal Ring Signal

Phone Note System

Your phone can handle a range of notes over two octaves.



Look at Table 2 to understand which notes and other notations correspond to which keys. Figure 13 also explains which key goes with which note on the keypad.

Pressing and holding a key gives you a long note.

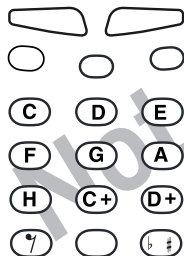

Figure 13. Keypad in musical notes

Simple Melody

This song corresponds to the C, D, and E tones on a music scale.

Creating Do-Re-Me

1. Select **Edit Melody** in the **Settings** menu.
Your display now looks like this.



2. Press **1**.

3. Press **2**.

4. Press **3**.

The display now looks like this:



5. Press **YES** to test the melody.

The phone plays the melody and asks you if you want to save it.

6. Press **YES** to save the melody as an alternative in the **Ring Type** menu.

Table 2. List of musical notation.

Press this:	To:
1-9	insert notes, where 1 gives a C and 9 a high D.
#	increase or decrease the pitch in half tone steps. Press once for sharp (#), twice for flat (b), three times to get the normal pitch.
*	insert a short pause (1/8).
↶ ↷	scroll within the melody. Press and hold to get to the beginning or end of the melody.
0	get either a higher or a lower octave for the note you have inserted. You know it is higher as a plus sign is added in front of the note name.
CLR	erase the note to the left of the cursor. If you press and hold CLR, the whole melody is erased.

Diverting Calls

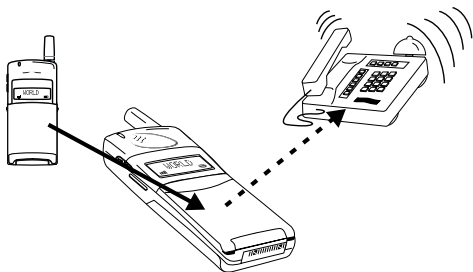

Diverting Calls

When supported by your service provider, you can use the **Divert** menu to divert (forward) your calls to another number, for example your voice mail or home phone.

Note!

If your SIM Card and your service provider support two lines, you need to set each line separately (see *Line 2 Option* on page 9).

The divert service lets you divert:

- **All calls:** regardless of if your telephone is turned on or off.
- **Unanswered calls:** if you do not answer within 30 seconds, if your phone is busy, turned off or out of range of a network.

You can divert calls from both the reduced and extended menu. In the reduced menu you only

divert all calls to one phone number. In the extended menu you decide how you want your divert, i.e. number and type of calls.

As a reminder, the display will inform you about any activated call divert each time you turn on the phone.

Diverting from Reduced Menu

1. Select the **Divert** menu.
2. You are prompted to enter a number (if you have not previously entered a number). Or you can press the left arrow key to enter a name.
3. Enter the desired number (or name) at the prompt and press **YES**.
4. There may be a short delay before the network responds and your display reads:

Please wait

Followed by a divert message and phone number.

Your standby display now looks like this:



The **Divert?** menu changes into **DivertOff?** when the divert is active.

Diverting from Extended Menu

1. Select the **DivertLine** menu.
2. Select a divert option.
3. Chose **Activate** and press **YES**.

You may now do one of the following:

- Enter a number at the prompt where you want your calls to be diverted, including the area code, and press **YES**.
- Press the left arrow key to enter a name from your phone book and press **YES**.
- Use the phone number that is suggested and press **YES**.

You will only get a number suggested if you activated the divert function before.

There may be a short delay before the network responds to your divert option, and

your display tells you when the divert is active (on or off).

Viewing Status of Call Divert

1. Select the **DivertLine** menu.
2. Select the divert option you wish to view and choose **GetStatus**.

There may be a short delay before the network responds, and your display tells you which divert is active (on or off).

Cancelling Call Divert

1. Select the **DivertLine** menu.
2. Select the divert option you wish to cancel and choose **Cancel**.

There may be a short delay before the network responds, but you will be prompted that your divert has been cancelled.

Protecting Your Keypad, Phone and SIM Card

Locks

Your phone has three types of locks:

- Keypad lock (does not protect in case of theft)
- Card lock
- Phone lock

The card and phone locks are found in the **Locks** menu and you find the keypad lock is in the **Settings** menu.

Keypad Lock

You can lock the keypad so that unintentional key action has no effect if the phone is turned on when you are carrying it in a handbag or pocket. When activated, the keypad lock is turned on 30 seconds after the last key action.

The keypad remains locked until you:

- answer or reject a call.
- unlock the keypad yourself.

Note!

You can always call the international emergency number 112 when the keypad is locked.

Setting the Keypad Lock

1. Select **Key Lock** in the **Settings** menu.
2. Select **Auto**.

To turn off the automatic keypad lock, select the **Off** option.

Unlocking Keypad

- Press **↩** and press **YES**.

Card Lock (SIM)

The card lock protects your SIM Card. When the card lock is active, your phone tells you to enter your PIN at startup.

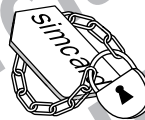

PINs and PUKs

When you buy your SIM Card, you obtain a four- to eight-digit PIN (Personal Identification Number) and a longer PUK (Personal Unblocking Key). If your SIM card allows it, you can turn off the card lock.

The PIN is the code that you enter to get access to and activate your subscription. PIN 2 is used for special functions, such as price.

The PUK (and PUK 2) is a longer code that helps you unlock your phone when you have forgotten the PIN (PIN 2).

Changing PIN

1. Select **CardLock** in the **Locks** menu.

2. Select **NewPIN**.

3. Enter the old PIN at the prompt and press **YES**.
4. Enter the new PIN and press **YES**.
5. Repeat the new PIN at the prompt and press **YES**.

Unblocking with PUK

If you enter the PIN incorrectly three times in a row, the display reads:

PUK:

1. Enter your PUK and press **YES**.
2. Enter a new PIN at the prompt and press **YES**.
3. Repeat the new PIN at the prompt and press **YES**.

If you enter both the PUK and the PIN correctly, the display reads:

New PIN

Phone Lock

The phone lock protects the phone against unauthorized use of the phone if it is stolen. The phone lock is not activated when you buy the phone.



These are the two types of phone lock:

Autolock: you need to enter the phone lock code every time you change SIM Card in the phone.

Full lock: you need to enter the phone lock code every time you turn on the phone.

Changing Phone Lock Code

1. Select **Phone Lock** in the **Locks** menu.
2. Select **New Code**.
3. Enter 0000 at the prompt (the factory default code) or your own code and press **YES**.
4. Key in a four- to eight- digit personal code at the prompt and press **YES**.
5. Repeat the new code at the prompt and press **YES**.

(Un)Locking Phone

1. Select **Phone Lock** in the **Locks** menu.
2. Select the desired lock option, for example **Auto Lock**.
3. Enter 0000 (the factory default code) or your own phone lock code at the prompt and press **YES**.

To unlock the phone, choose **Unlock** in the **Locks** menu.

Barring Calls – Restricting Calls

Barring Calls

The call barring service lets you control which kind of calls can be made to or from your phone. This is convenient if you lend your phone to somebody else. This feature is GSM service dependent.

Barring Options

Your phone supports the following barring options (but your subscription might not support all):

- all outgoing calls – you cannot make any calls.
- all outgoing international calls – you cannot make any international calls.
- all outgoing international calls except to your home country – you cannot make any international calls except to the SIM Card home country.

- all incoming calls – you will not receive any calls.
- all incoming calls when you are abroad – you will not receive any calls when abroad.

Note!

To activate any of the barring functions, you need the password that comes with your subscription.

Activating Call Bars for Any Call Type

1. Select either **Incoming** or **Outgoing** call bars from the **Barring** menu
2. Select the barring option you want.
3. Select **Activate**.
4. Enter your password (provided with your subscription) and press **YES**.

There may be a short delay before the network responds and your display tells you which call bars have been activated.

Press **CLR** to stop the responses from the network.

Cancelling All Call Bars

1. Select the **Cancel All** option in the **Barring** menu.
2. Enter your password at the prompt and press **YES**.

There may be a short delay before the network responds and your display tells you which call bars have been cancelled.

Press **CLR** to stop the responses from the network.

Customizing Your Reduced Menu

Customizing Menus

The reduced menu system can be customized by adding or deleting other menus or sub-menus. You cannot delete the standby display or **Menu Size** from the reduced menu system. When you are scrolling through the menus in customize mode, the menu names will be either flashing or solid meaning that you may either add or delete the menu from the reduced system.

When you add a menu to the reduced menu system and accept the position the phone suggests, the menu is placed in the third position to the right of the standby display. See the separate leaflet for a description of what the reduced menu system looks like if the **Settings** menu has been added.

Adding Menus

1. Select **Edit Menus** in the **Customize** menu.
2. Scroll to and select the menu or sub-menu that you want to add (a menu where the name is blinking).
3. Press and hold **YES** for three seconds.
4. Press **YES** to accept the position (if you wish to change the position, see section below).
5. Repeat steps 2 and 3 to add more menus.

6. Press **NO** or **CLR**.
7. Press **YES** to update.

Note!

You can select sub-menus from the **Settings** and the **Locks** menus.

Changing Menu Position

- Press **NO** when the **AcceptPos?** prompt appears. The display could now look like this:

Store>04?

This display means that the menu that you want to add will be in the fourth (04) position to the right (>) in the reduced menu system.

See the table below on how to use the keys to change the position in the menu.

Press this:	To:
*	toggle between left and right position.
1-9	enter a position number (you cannot have a menu in position 00).
YES	accept position.
NO	reject a position or return to edit mode.
CLR	return to the suggested position.

Deleting Menus

1. Select **Edit Menus** in the **Customize** menu.
2. Scroll to the menu you want to delete (a menu where the name is not flashing).
3. Press **YES** for three seconds.
The menu name now starts flashing meaning that it is now taken away from the reduced menu system.
4. Repeat steps 2 and 3 to delete more menus.
5. Press **NO** or **CLR**.
6. Press **YES** to update.

Resetting Menus to Original

- Choose **Reset** in the **Customize** menu.
The reduced menu structure is reset to its original positions (see separate leaflet).

Sending and Receiving Text Messages

Text Messages

The Short Message Service (SMS) function allows you to send and receive text messages that contain up to 160 characters. Text messages can be received when the phone is in standby mode, when you are engaged in a call, or when incoming calls are diverted to another phone number. If you have had your phone turned off for a while, the network keeps track of the message and sends it to your phone as soon as it is turned on.

After a message is received, it is left in the phone's memory, which is similar to a computer's working memory. The message remains in the phone's memory until you read it. You can even turn off the phone and the message still remains intact. If you, on the other hand, change SIM Card, you lose the unread message. This is because messages are personal.

Note!

You need to set the service centre number before you can **send** any messages. If you only want to receive messages, you do not need to do anything.

Checking Subscription

- Call your service provider to see which services your subscription supports, or check the service provider's manual.

Setting Service Centre Address

1. Check the service centre address (number) for your service provider.
2. Select **Options** in the **Send** menu.
3. Select **Serv Cent.**
4. Enter the service centre address and the (+) sign and press **YES**.

Sending SMS

1. Select **New** in the **Send** menu.
2. Enter your message and press **YES**. You can also enter a phone number.
3. Enter the phone number, or press the left arrow key to enter a name you want to send to and press **YES**.

The display now looks like this:

 Sent!

If your message does not go through, it is sent back to you.

Setting Duration of Message

1. Select **Options** in the **Send** menu.
2. Select **Valid Per.**
3. Select how long you want the message to be repeated.

The service centre repeats the message for the set duration or until the receiver can receive it.

Other Message Types

You can send SMS from your phone to the service centre and the service centre can change the message into the following types (if supported):

E-Mail

The E-mail address cannot contain more than 20 characters.

Telex

Fax

Groups 3 and 4.

X400

Voice

Changing Message Type

1. Select **Options** in the **Send** menu.
2. Select **Msg Type**.
3. Select the message type you want.

Receiving a Message

When you receive a message, the display looks like this:



At the same time you hear a signal and the green light on the top of the phone flashes.

Reading an Incoming Message

1. Press **YES** when you receive a message.
The display shows you the date of the incoming SMS, you can see the time by pressing *****.

2. Press **YES**.
The display shows you from which phone number the message has been sent, or the name if stored in your phone book. The display could now look like this:

Jenny

The arrow shows you that you can start scrolling through the message with the right arrow key.

3. Press the right arrow key to read the message.

When you have read a message, you can do one of the following:

- **Call** a phone number in the message by pressing **YES**.
- **Erase** the message by pressing **YES** at the erase prompt.
- **Store** the message by pressing **NO** at the erase prompt (you may get a reply prompt if the sender has requested a reply). Press **YES** at the

Store prompt and the message is stored on the SIM Card.

Erasing a Message

- Press **CLR** at any time during the message and answer **YES** on the question prompt.

Reading an Old Message

1. Select the **Read** menu.
2. Scroll to the message you want to read and press **YES**.
3. Read through the message by pressing the right arrow key.

Receiving Area Information

Area Information

The SMS function is a personal service with messages directed to you. However, Area Information is a broadcast type message that is sent to all subscribers in a certain cell, for example a section of a city, at the same time. You can set your phone to receive only those messages you want to listen to, e.g. the local weather forecast or the local traffic report. Each message is identified by a three-digit code. Check with your service provider for which message types are available in your network.

When you receive an AI the display looks like this:



The default setting for the phone is that the AI service is turned off.

At present the following message types exist:

Code	Title
000	Index
010	News Flashes
020	Hospitals
022	Doctors
024	Pharmacy
030	Long-distance road reports
032	Local road reports
034	Taxis
040	Weather
050	District
052	Network information
054	Operator services
056	Directory enquiries (national)
057	Directory enquiries (international)
058	Customer care (national)
059	Customer care (international)

Activating the Area Information

- Select **On** in the **AreaInfo** sub-menu.

Adding a Code

1. Select **EditList** in the **AreaInfo** sub-menu.

2. Press the right arrow key to find the first empty position and press **YES**.
3. Enter a new code and press **YES**.
The display could now look like this if you have added the pharmacy title to the second position:

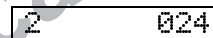

Erasing a Code

1. Select **Edit List** in the **AreaInfo** sub-menu.
2. Scroll to the position (to the left in the display) you wish to erase and press **YES**.
3. Press **YES** at the erase prompt.

Changing a Code

1. Select **Edit List** in the **AreaInfo** sub-menu.
2. Scroll to the position (to the left in the display) you wish to change and press **YES**.
3. Scroll to **New Code** and press **YES**.
4. Enter the new code and press **YES**.

Knowing Cost and Duration of Calls

Call Time

Your phone can keep track of the duration of calls in three ways. Select the Info menu to check:

- **Total Calls:** This feature shows the total time of all calls in hours and minutes since the counter was last set.
- **Outgoing Calls:** This feature tracks the time of all your outgoing calls in hours and minutes since the counter was last set.
- **Last Call:** This feature tracks the duration of your last call in minutes and seconds. This information appears in the display after a call has been finished.

When a call finishes you look at the display to find out how long your call lasted.

Resetting a Call Unit Counter

1. Select the **Info** menu.
2. Scroll to the counter option you want to set or reset and press **YES**.
3. Press **YES** at the reset prompt.



Call Cost

The duration of calls can be displayed as cost instead of time while a call is in progress, if your network and SIM Card support this feature. You can specify any rate you wish.

Activating the Call Cost Function

1. Select **Call Info** from the **Settings** menu.
2. At the prompt **Cost?** press **YES**.

Specify the Price per Call Unit

1. Select **Set Price?** From the **Info** menu.
2. At the prompt **Curr:** enter the currency (GBP for Pounds Sterling, for instance) or disregard. Press **YES**.
3. Enter the call unit rate. To enter a decimal point, press *****.

4. Press **YES**.
5. Enter the PIN2 and press **YES**.

Viewing the Call Cost

When you end a call, the cost (or the number of call units) is displayed. To view the total cost (or the total number of call units), select the **Info** menu.

Setting a Cost Counter

If you have activated the call cost function, you can also specify a cost limit. The cost of each call will then be deducted from the specified amount. 30 seconds before the amount equals zero, you will hear two warning beeps.

Specifying a Cost Limit

1. Select **Credit** from the **Info** menu.
2. Select **New Credit**.
3. Enter the cost limit and press **YES**.
4. Enter the PIN2 and press **YES**.

Viewing Remaining Credit

You can view the remaining amount of credit in the display when you end the call. You can also select the **Info** menu and then scroll to the **Credit** function. The word **Credit** and the remaining amount toggle in the display.

Specific Data Menus

Having Data Menus On

Your phone is prepared to send and receive data and fax messages in connection with a *Mobile Office* kit. You need to activate the data menus to send data and faxes.

Note!

Instructions on how to use the **Speech>FAX** and **Next Call** menus are contained in the *Mobile Office* kit.

Activating Data Menus

1. Select **Data Menus** in the **Settings** menu.
2. Select the **On** option.

Your phone will now have a new menu structure in the extended mode. All data menus are marked with a star * in the leaflet.

Diverting Fax and Data Calls

You can choose to divert the following, each to a different telephone number if you wish:

- Fax calls
- Data calls
- All numbers (including speech calls)

Diverting Data Calls

1. Make sure the **Data** menus are on.
2. Select the **DivertData** menu.
3. Select **Activate**.

You may now do one of the following:

- Enter the number to which you want your calls to be diverted, including the area code, and press **YES**.
- Press the left arrow key to enter a name from your phone book and press **YES**.
- Use the phone number that is suggested to you and press **YES**.

A suggested number only appears if you activated the divert function before.

There may be a short delay before the network responds to your divert option.

Diverting Fax Calls

1. Make sure the **Data** menus are on.
2. Select the **Divert Fax** menu.
3. Select **Activate**.

You may now do one of the following:

- Enter the number to which you want your calls to be diverted, including the area code, and press **YES**.
- Press the left arrow key to enter a name from your phone book and press **YES**.
- Use the phone number that is suggested to you and press **YES**.

A suggested number only appears if you activated the divert function before.

There may be a short delay before the network responds to your divert option.

Other Networks

Choosing Network

When you turn on the phone, it selects its home network. If this is not within range, you might not be able to get any reception. If you are abroad, you can choose a different network, provided your service provider has an agreement allowing you to use the network. This is called roaming.

When you select the Networks menu, the phone automatically searches for all networks present in the area. Each network that is found has a status indication telling you whether the network is available or forbidden.

See the list below for a description of the status indication:

Display:	Meaning:
Network and #	home network
Network and *	currently used network
Network and A	other available networks
Network and S	other available network (given priority by your home service provider)
Network and F	forbidden networks
Auto	automatic network search

Note!

The status of forbidden networks can change, so it is important that you make a network search to update the list, especially when you are visiting another country.

Auto is the basic setting for the network search and selection. This setting means that your phone takes care of all the network search and selection.

Selecting a Network

1. Select the **Networks** menu.
The phone performs a network search and the display shows the current network followed by the network list.
2. Scroll through the network list to see which networks are available.
3. Press **YES** to select a network.

When you have made a network selection, **Networks?** is shown whenever the phone cannot contact the desired network. You can now either:

- Select a new network.
- Set the phone to the automatic search mode.

Setting Phone to Automatic Network Search

1. Select the **Networks** menu.
2. Scroll, after the search, to **Auto** and press **YES**.

Index

A

Alarm	
setting	15
snooze	15
turning off	15, 16
Answer mode	
about	16
changing	16
Answering calls	7
Antenna	6
Area information	27
about	27
activating	27
adding codes	27
changing codes	27
erasing codes	27
Assembly instructions	1
Autolock	22

B

Barring calls	
about	23
activating	23
cancelling	23
Battery	6
about	3
attaching	2
removing	2
status	5

Battery icon	5
Busy tone	8

C

Call wait	8
Call waiting	
about	16
activating	16
Calling information	17
Calling line identification	8
Calls	
answering	7
barring	23
conference	9
costs of	28
data	29
diverting, about	19
duration	28
emergency	7
ending	7
hold	8
international	7
making	7
receiving	7
rejecting	8
restricting	23
transferring	9
Charger	
connecting	2
connector	6
disconnecting	2

function	3
CLI	8, 14
Clock	
setting	15
viewing	15
Conference calls	9
Cost counter	28
Credit	
remaining	28

D

Data calls	
diverting	29
Dialling	5
Display	6
information	5
language	16
Divert icon	5
Divert line 2	9
Diverting calls	19
cancelling	20
extended menu	19
reduced menu	19
view status	20

E

E-mail	25
Earpiece	6
Emergency calls	7
Enter	11

Erasing text message	26
Extended menus	11
<hr/>	
F	
Fax	25
diverting	29
Flip	6
Full lock	22
<hr/>	
G	
Glossary	11
Greeting	
changing	16
<hr/>	
H	
Handsfree options	16
Handsfree types	
changing	16
Handsfree types	16
<hr/>	
I	
International prefix	7
<hr/>	
K	
Key sound	
changing	17
Keypad	6
lock	21
unlock	21
Keypad lock	
turning off	21

L

Language	
display	16
display, changing	16
Language reset	16
Last dialled	
about	14
numbers recall	14
Letter icon	5
Letters, entering	13
Line 2	9
Line indicator icon	5
Locks	
about	21
keypad	21
phone	21
SIM	21

M

Mail alert	17
Mains	2
Making	
ring signal	18
Making calls	7
Melody	
simple	18
Memory	
phone	12
SIM	12
Menu system	
about	11
navigating	11
Menus	

adding	24
changing position	24
customizing	24
deleting	24
resetting	24
Message type	
changing	26
Message types	
e-mail	25
fax	25
telex	25
voice	25
X400	25
Messages	
See Text messages	
Microphone	6
Microphone channel	6
Muting	8

N

Network	
selecting	30
Network icon	5
Nickel metal hydride	3
Noting music	18

P

Phone	
holding	7
locking	22
locking code	22
turning off	4
unlocking	22
Phone book	12

about	12
changing	14
Phone clip	6
Phone icon	5
Phone number	
deleting	14
hiding	8
showing	8
storing	12
PIN	
about	21
changing	21
PIN 2	21
Position recall	
from phone	13
from SIM	13
Protecting phone	21
PUK	21
about	21

R

Recalling	
by name	13
by number	13
Receiving calls	7
Reduced menus	11
Rejecting calls	8
Resetting menus	24
Ring signal	18
icon	5
personal	18
See Ring volume	
Ring type	

about	15
changing	15
Ring volume	
changing	15
muting	15
Ringing alarm	15
Roaming	30

S

Scroll	11
Select	11
Service center	25
Service centre	
setting	25
Setting keypad lock	21
Signal strength icon	5
SIM Card	
about	3
inserting	1
protecting	21
release button	1, 6
removing	1
Simple melody	18
SMS	
See Text message	
Snooze	15
Speed dialling	13
Stopping calls	
See Barring calls	
Storing numbers	
phone memory	12
SIM Card	12

T

Telex	25
Text message	
about	25
erasing	26
going through	25
reading	26
saving	26
sending	25
types	25
Transferring calls	9
Transmission problems	16
Turning off phone	4
Two calls	8
Type 1 and 2	16

U

Unanswered calls	14
Unblocking	21

V

Voice (message)	25
Volume	
ear, changing	15
Volume keys	6

X

X400	25
------	----

Not for Commercial Use
Ericsson Mobile Communications AB